

Autoenge Solutions

Soluções Metrológicas e Instrumentação Industrial

Autoenge Solutions

Soluções Metrológicas e Instrumentação Industrial

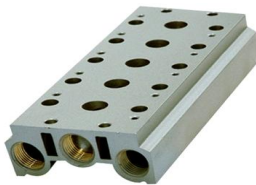

Autoenge Solutions

Soluções Metrológicas e Instrumentação Industrial



	VÁLVULA PILOTO 3 E 5 VIAS	01-05
	VÁLVULA SOLENÓIDE 3 E 5 VIAS	06-10
	VÁLVULA 5 VIAS CENTRO FECHADO	11-13
	VÁLVULA NAMUR	14-15
	BLOCO MANIFOLD	16
	VÁLVULA 3 VIAS SÉRIE 3V1	17
	VÁLVULA SOLENÓIDE 2/2 VIAS SÉRIE 2V	18-19
	VÁLVULA SOLENÓIDE 2/2 VIAS SÉRIE 2W	20
	VÁLVULA SOLENÓIDE 2/2 VIAS SÉRIE 2L	21
	VÁLVULA PILOTO 2/2 VIAS SÉRIE 2Q	22
	VÁLVULA FILTRO MANGA	23
	VÁLVULA ANGULAR 2/2 VIAS	24
	VÁLVULA ALAVANCA 5/2 VIAS	25
	VÁLVULA ROTATIVA 4/2 VIAS	26
	VÁLVULA BOTÃO 3 E 5 VIAS	27
	VÁLVULA PEDAL	28-29
	REGULADOR DE FLUXO	30
	VALVULA DESLIZANTE	30
	VALVULA DE ESCAPE RÁPIDO, ELEMENTO "OU"	30
	VÁLVULA DE RETENÇÃO	30
	PURGADOR ELETRÔNICO	30

VÁLVULA PILOTO 3/2 VIAS



3A210-06



3A220-08

3A210-06

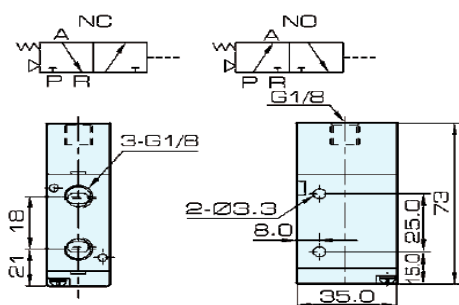

3A210-08

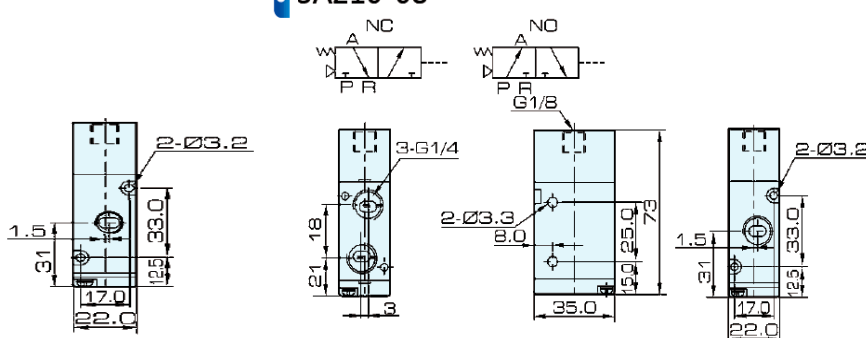

3A220-06

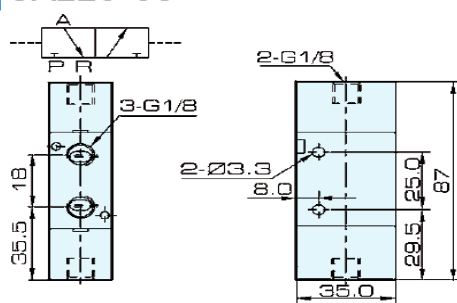

3A220-08

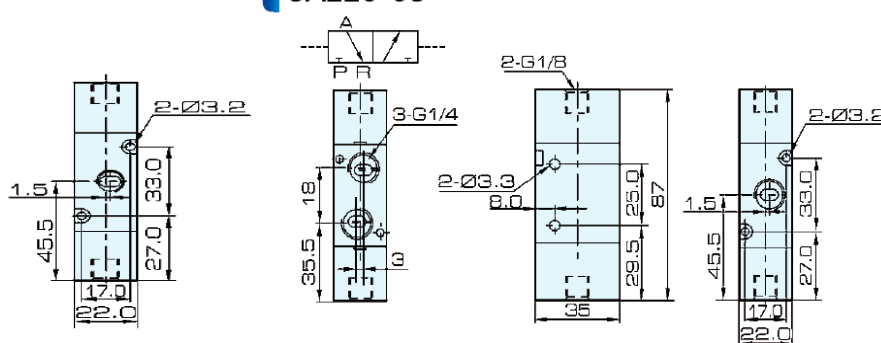

ESPECIFICAÇÕES

MODELO	3A210-06	3A210-08	3A220-06	3A220-08
ENTR/SAIDA	1/8"	1/4"	1/8"	1/4"
ESCAPE	1/8"	1/8"	1/8"	1/8"
ÁREA EQUIVALENTE	14mm ²	16mm ²	14mm ²	16mm ²
COEFICIENTE VAZÃO	0,78	0,89	0,78	0,89
FLUIDO	AR FILTRADO (40 µm)			
PRESSÃO	0,15 ~ 0,8 Mpa			
PRESSÃO MÁX.	1,2 MPa			
TEMPERATURA	5 ~ 50 °C			
FREQUÊNCIA	5 CICLOS/s			
TEMPO RESPOSTA	0,05 s			

VÁLVULA PILOTO 3/2 VIAS



3A310-10



3A320-10

3A310-08

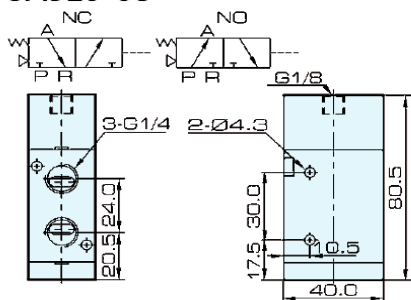

3A310-10

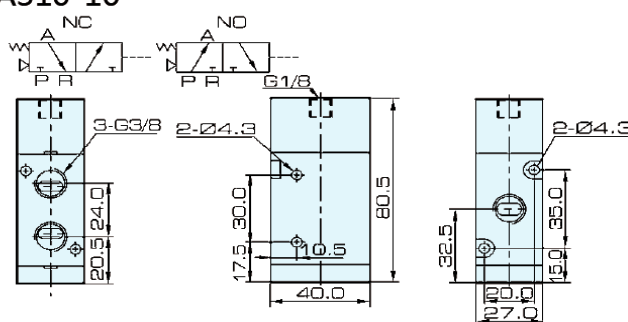

3A320-08

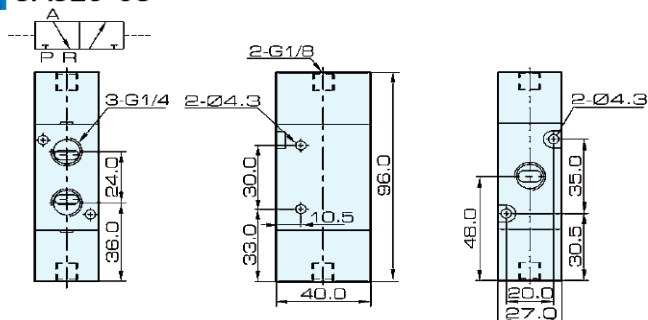

3A320-10

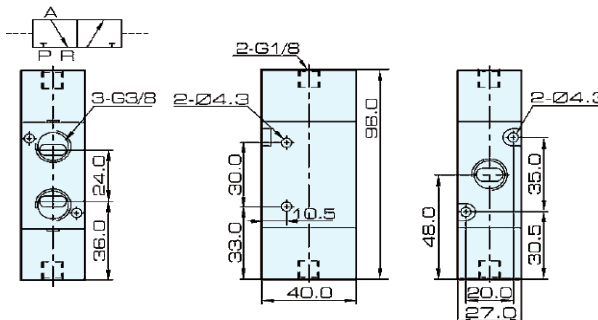

ESPECIFICAÇÕES

ESPECIFICAÇÕES				
MODELO	3A310-08	3A310-10	3A320-08	3A320-10
ENTR/SAIDA	1/4"	3/8"	1/4"	3/8"
ESCAPE	1/4"	3/8"	1/4"	1/4"
ÁREA EQUIVALENTE	25mm ²	30mm ²	25mm ²	30mm ²
COEFICIENTE VAZÃO	1,40	1,68	1,40	1,68
FLUIDO	AR FILTRADO (40 µm)			
PRESSÃO	0,15 ~ 0,8 Mpa			
PRESSÃO MÁX.	1,2 MPa			
TEMPERATURA	5 ~ 50 °C			
FREQUÊNCIA	5 CICLOS/s			
TEMPO RESPOSTA	0,05 s			

VÁLVULA PILOTO 5/2 VIAS



4A210-08



4A220-06

4A210-06

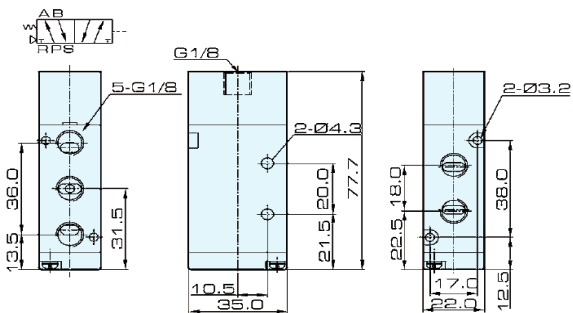

4A210-08

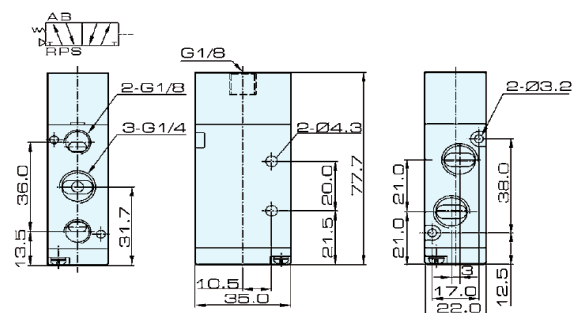

4A220-06

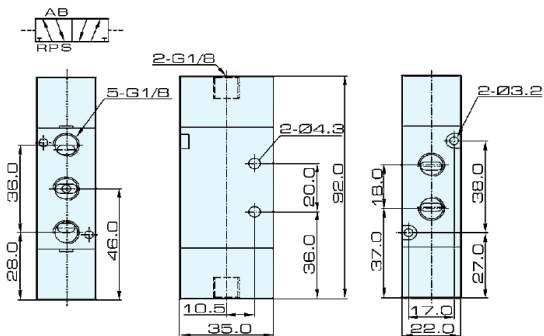

4A220-08

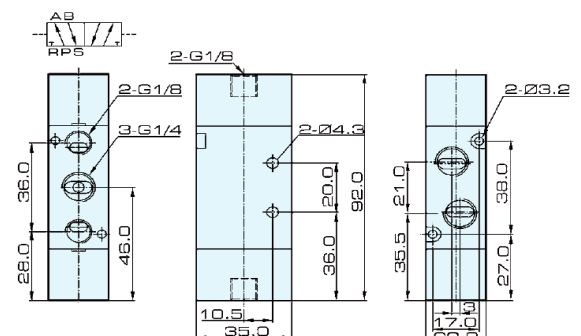

ESPECIFICAÇÕES

MODELO	4A210-06	4A210-08	4A220-06	4A220-08
ENTR/SAIDA	1/8"	1/4"	1/8"	1/4"
ESCAPE	1/8"	1/8"	1/8"	1/8"
ÁREA EQUIVALENTE	14mm ²	16mm ²	14mm ²	16mm ²
COEFICIENTE VAZÃO	0,78	0,89	0,78	0,89
FLUIDO	AR FILTRADO (40 µm)			
PRESSÃO	0,15 ~ 0,8 Mpa			
PRESSÃO MÁX.	1,2 MPa			
TEMPERATURA	5 ~ 50 °C			
FREQUÊNCIA	5 CICLOS/s			
TEMPO RESPOSTA	0,05 s			

VÁLVULA PILOTO 5/2 VIAS



4A310-08



4A320-10

4A310-08

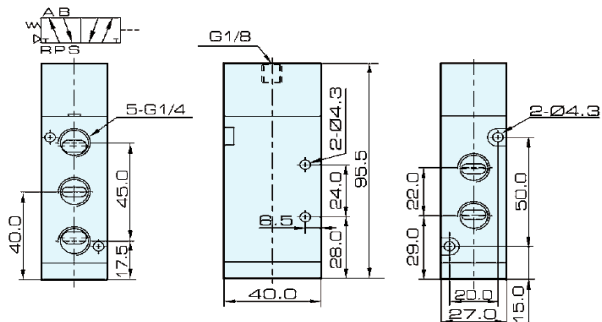

4A310-10

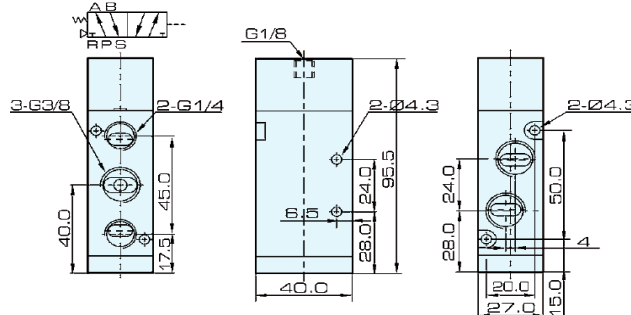

4A320-08

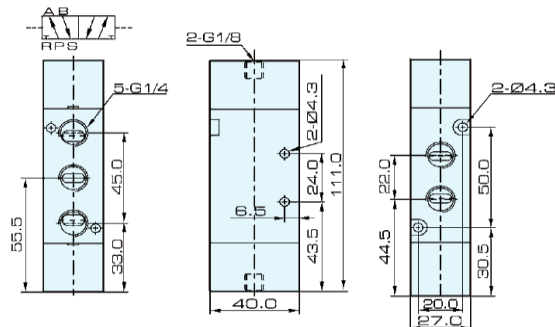

4A320-10

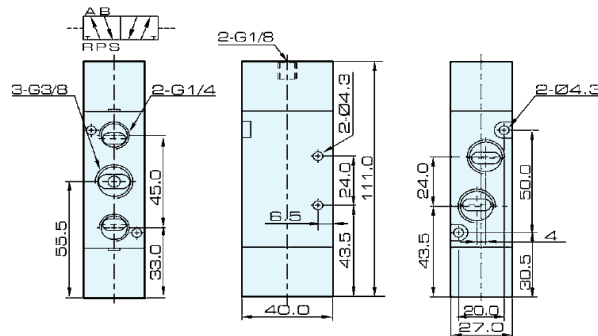

ESPECIFICAÇÕES

MODELO	4A310-08	4A310-10	4A320-08	4A320-10
ENTR/SAIDA	1/4"	3/8"	1/4"	3/8"
ESCAPE	1/4"	1/4"	1/4"	1/4"
ÁREA EQUIVALENTE	25mm ²	30mm ²	25mm ²	30mm ²
COEFICIENTE VAZÃO	1,40	1,68	1,40	1,68
FLUIDO	AR FILTRADO (40 µm)			
PRESSÃO	0,15 ~ 0,8 Mpa			
PRESSÃO MÁX.	1,2 MPa			
TEMPERATURA	5 ~ 50 °C			
FREQUÊNCIA	5 CICLOS/s			
TEMPO RESPOSTA	0,05 s			

VÁLVULA PILOTO 3/2 VIAS



3A410-15



3A420-15



4A410-15



4A420-15

3A410-15

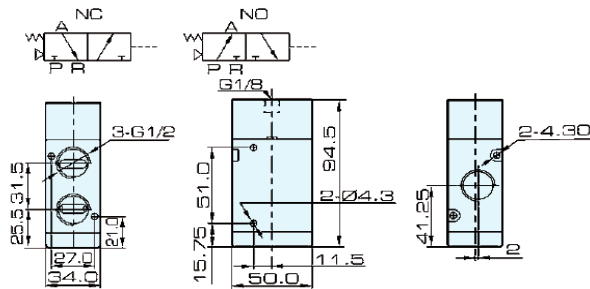

3A420-15

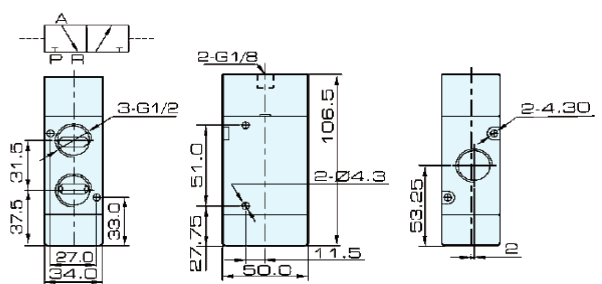

4A410-15

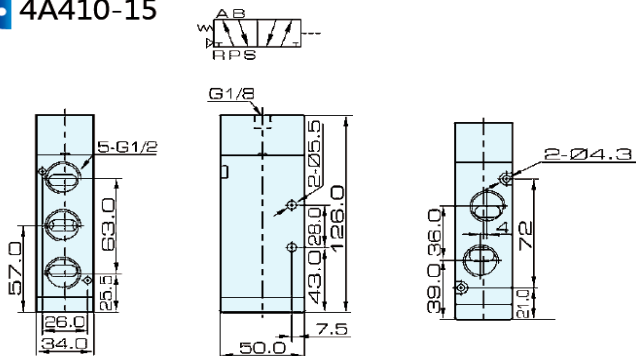

4A420-15

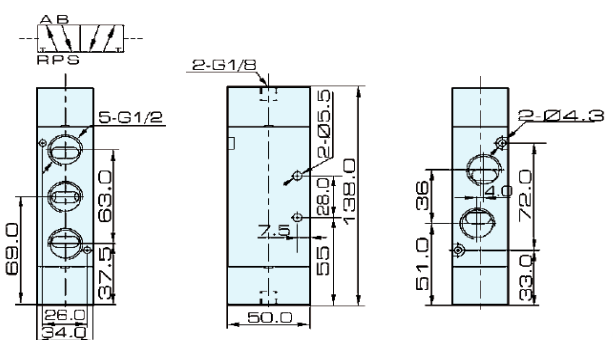

ESPECIFICAÇÕES

MODELO	3A410-15	3A420-15	4A410-15	4A420-15
ENTR/SAIDA	1/2"			
ESCAPE	1/2"			
ÁREA EQUIVALENTE	50mm ²			
COEFICIENTE VAZÃO	2,79			
FLUIDO	AR FILTRADO (40 µm)			
PRESSÃO	0,15 ~ 0,8 Mpa			
PRESSÃO MÁX.	1,2 MPa			
TEMPERATURA	5 ~ 50 °C			
FREQUÊNCIA	5 CICLOS/s			
TEMPO RESPOSTA	0,05 s			

VÁLVULA SOLENÓIDE 3/2 VIAS



3V210-08



3V220-08

3V210-06

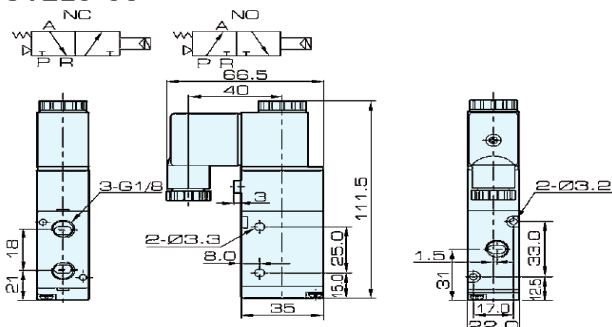

3V210-08

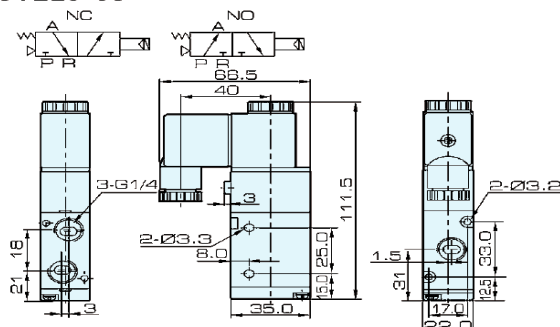

3V220-06

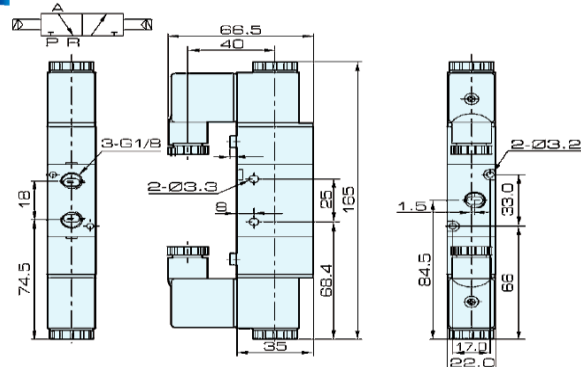

3V220-08

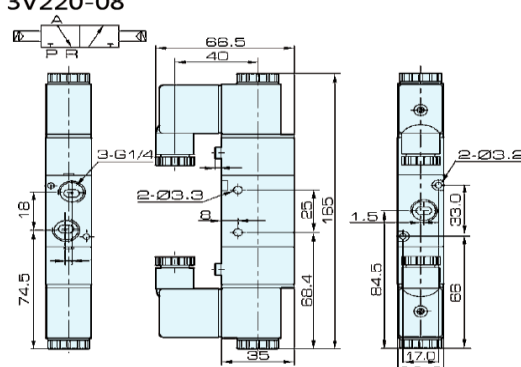

ESPECIFICAÇÕES

MODELO	3V210-06	3V210-08	3V220-06	3V220-08
ENTRADA/SAIDA	1/8"	1/4"	1/8"	1/4"
ESCAPE	1/8"	1/8"	1/8"	1/8"
ÁREA EQUIVALENTE	14mm ²	16mm ²	14mm ²	16mm ²
COEFICIENTE VAZÃO	0,78	0,89	0,78	0,89
FLUIDO	AR FILTRADO (40 µm)			
PRESSÃO	0,15 ~ 0,8 Mpa			
PRESSÃO MÁX.	1,2 MPa			
TEMPERATURA	5 ~ 50 °C			
CLASSE PROTEÇÃO	IP 65			
TENSÃO	12DC - 24DC - 110AC - 220 AC			
FREQUÊNCIA	5 CICLOS/s			
TEMPO RESPOSTA	0,05 s			

VÁLVULA SOLENÓIDE 5/2 VIAS



4V210-08



4V220-08

4V210-06

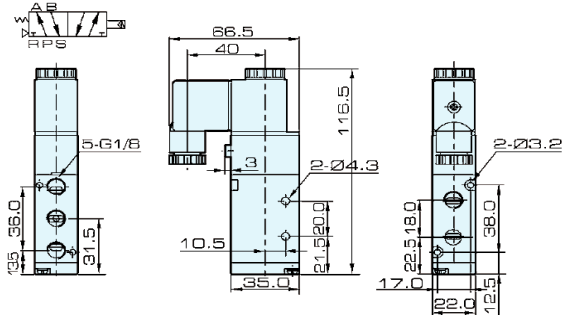

4V210-08

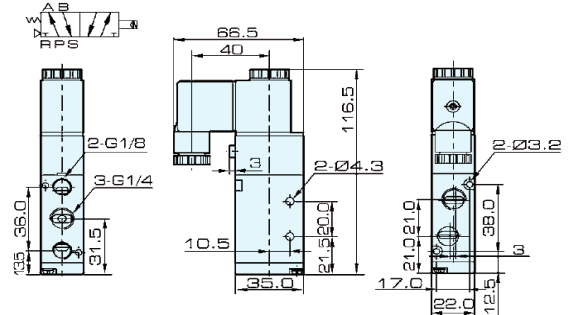

4V220-06

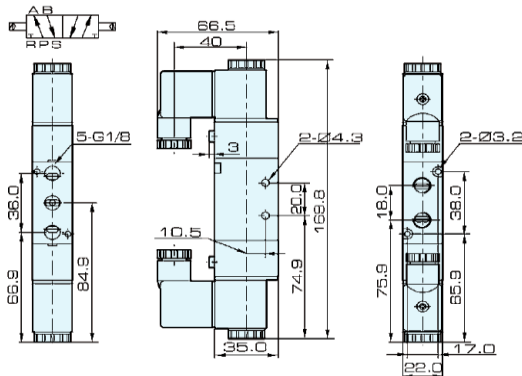

4V220-08

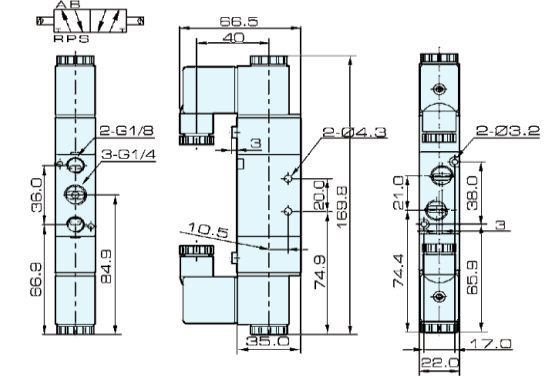

ESPECIFICAÇÕES

MODELO	4V210-06	4V210-08	4V220-06	4V220-08
ENTR/SAIDA	1/8"	1/4"	1/8"	1/4"
ESCAPE	1/8"	1/8"	1/8"	1/8"
ÁREA EQUIVALENTE	14mm ²	16mm ²	14mm ²	16mm ²
COEFICIENTE VAZÃO	0,78	0,89	0,78	0,89
FLUIDO	AR FILTRADO (40 µm)			
PRESSÃO	0,15 ~ 0,8 Mpa			
PRESSÃO MÁX.	1,2 MPa			
TEMPERATURA	5 ~ 50 °C			
CLASSE PROTEÇÃO	IP 65			
TENSÃO	12DC - 24DC - 110AC - 220 AC			
FREQUÊNCIA	5 CICLOS/s			
TEMPO RESPOSTA	0,05 s			

VÁLVULA SOLENÓIDE 3/2 VIAS



3V310-10



3V320-08

3V310-08

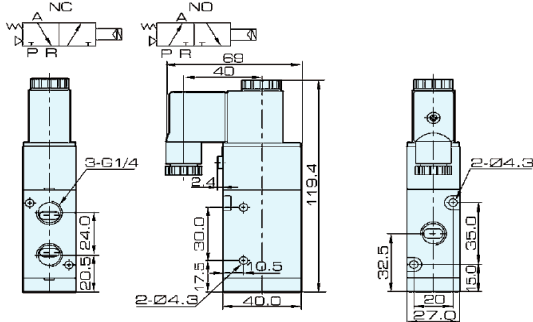

3V310-10

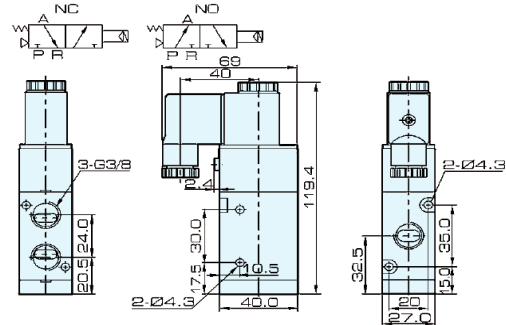

3V320-08

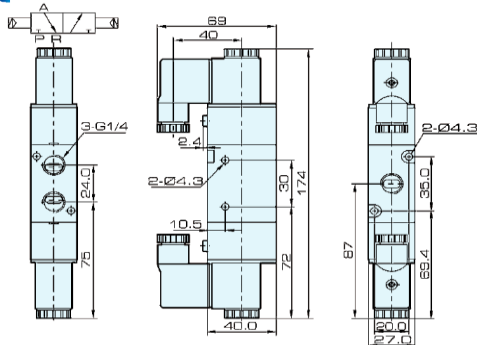

3V320-10

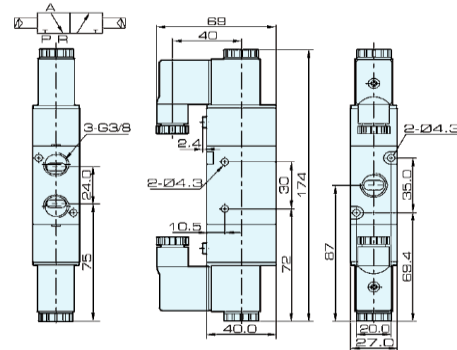

ESPECIFICAÇÕES				
MODELO	3V310-08	3V310-10	3V320-08	3V320-10
ENTRADA/SAIDA	1/4"	3/8"	1/4"	3/8"
ESCAPE	1/4"	1/4"	1/4"	1/4"
ÁREA EQUIVALENTE	25mm ²	30mm ²	25mm ²	30mm ²
COEFICIENTE VAZÃO	1,40	1,68	1,40	1,68
FLUIDO	AR FILTRADO (40 µm)			
PRESSÃO	0,15 ~ 0,8 Mpa			
PRESSÃO MÁX.	1,2 MPa			
TEMPERATURA	5 ~ 50 °C			
CLASSE PROTEÇÃO	IP 65			
TENSÃO	12DC - 24DC - 110AC - 220 AC			
FREQUÊNCIA	5 CICLOS/s			
TEMPO RESPOSTA	0,05 s			

VÁLVULA SOLENÓIDE 5/2 VIAS



4V310-10



4V320-08

4V310-08

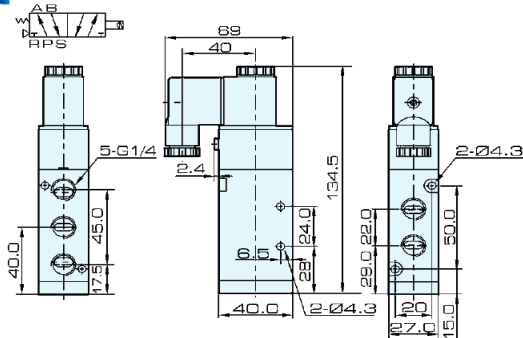

4V310-10

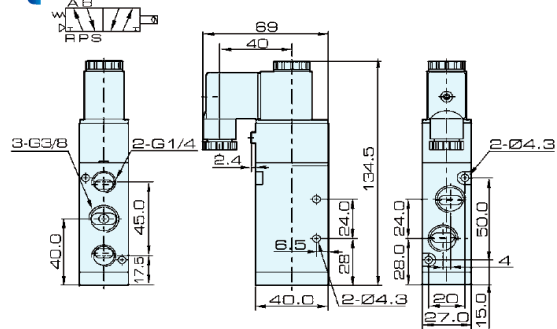

4V320-08

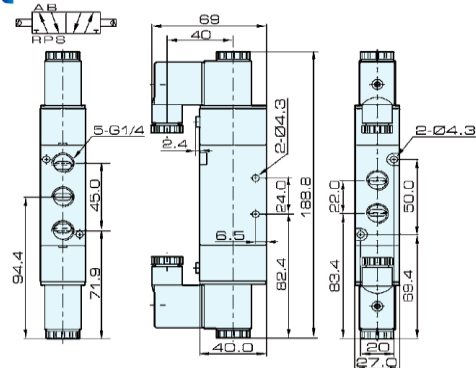

4V320-10

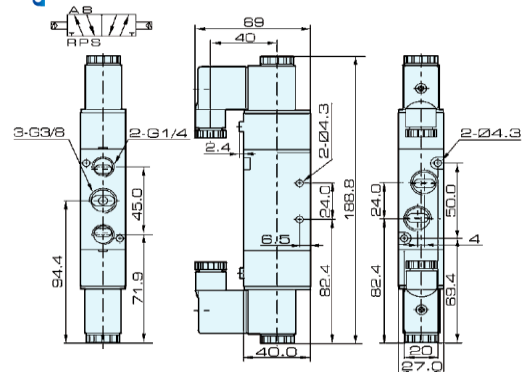

ESPECIFICAÇÕES

MODELO	4V310-08	4V310-10	4V320-08	4V320-10
ENTRADA/SAIDA	1/4"	3/8"	1/4"	3/8"
ESCAPE	1/4"	1/4"	1/4"	1/4"
ÁREA EQUIVALENTE	25mm ²	30mm ²	25mm ²	30mm ²
COEFICIENTE VAZÃO	1,40	1,68	1,40	1,68
FLUIDO	AR FILTRADO (40 µm)			
PRESSÃO	0,15 ~ 0,8 Mpa			
PRESSÃO MÁX.	1,2 MPa			
TEMPERATURA	5 ~ 50 °C			
CLASSE PROTEÇÃO	IP 65			
TENSÃO	12DC - 24DC - 110AC - 220 AC			
FREQUÊNCIA	5 CICLOS/s			
TEMPO RESPOSTA	0,05 s			

VÁLVULA SOLENÓIDE 3/2 VIAS

VÁLVULA SOLENÓIDE 5/2 VIAS



3V410-15

3V420-15



4V410-15

4V420-15

3V410-15

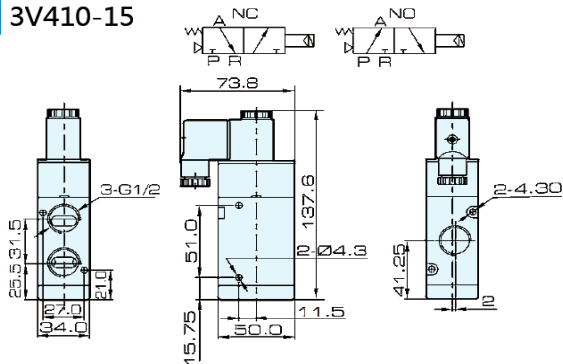

3V420-15

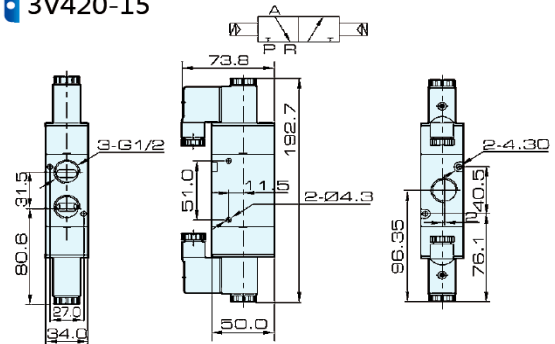

4V410-15

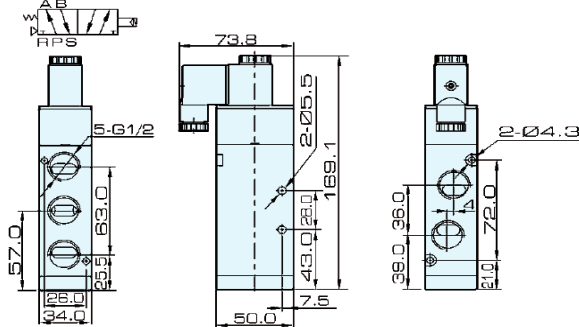

4V420-15

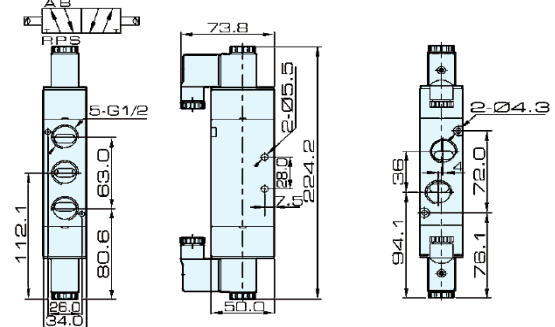

ESPECIFICAÇÕES

	3V410-15	3V420-15	4V410-15	4V420-15
MODELO	3V410-15	3V420-15	4V410-15	4V420-15
ENTR/SAIDA	1/2"			
ESCAPE	1/2"			
ÁREA EQUIVALENTE	50mm ²			
COEFICIENTE VAZÃO	2,79			
FLUIDO	AR FILTRADO (40 µm)			
PRESSÃO	0,15 ~ 0,8 Mpa			
PRESSÃO MÁX.	1,2 MPa			
TEMPERATURA	5 ~ 50 °C			
FREQUÊNCIA	5 CICLOS/s			
TEMPO RESPOSTA	0,05 s			

VÁLVULA SOLENÓIDE 5/3 VIAS CENTRO FECHADO



4A230C-08



4V230C-06

4A230-06

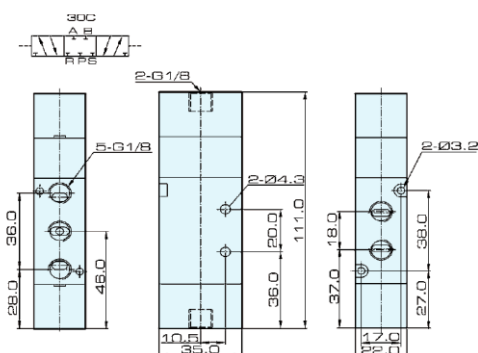

4A230-08

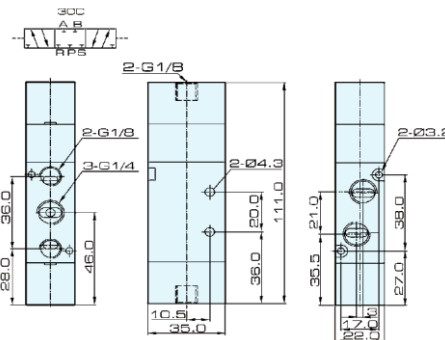

4V230-06

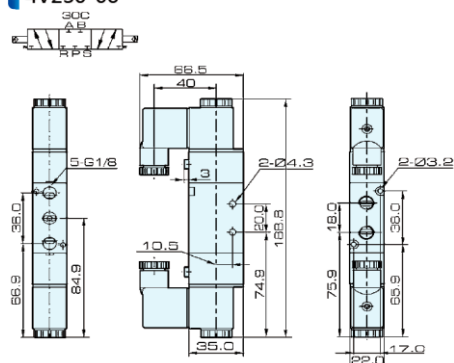

4V230-08

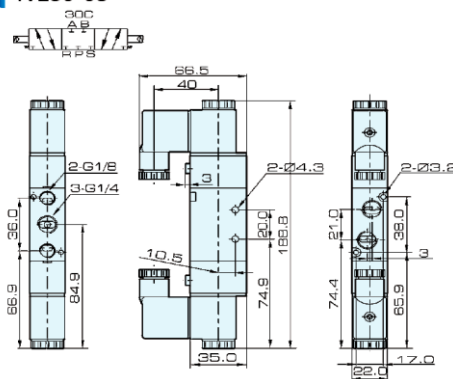

ESPECIFICAÇÕES

MODELO	4A230C-06	4A230C-08	4V230C-06	4V230C-08
ENTR/SAIDA	1/8"	1/4"	1/8"	1/4"
ESCAPE	1/8"	1/8"	1/8"	1/8"
ÁREA EQUIVALENTE	14mm ²	16mm ²	14mm ²	16mm ²
COEFICIENTE VAZÃO	0,78	0,89	0,78	0,89
FLUIDO	AR FILTRADO (40 µm)			
PRESSÃO	0,15 ~ 0,8 Mpa			
PRESSÃO MÁX.	1,2 MPa			
TEMPERATURA	5 ~ 50 °C			
CLASSE PROTEÇÃO	IP 65			
TENSÃO	12DC - 24DC - 110AC - 220 AC			
FREQUÊNCIA	5 CICLOS/s			
TEMPO RESPOSTA	0,05 s			

VÁLVULA SOLENÓIDE 5/3 VIAS CENTRO FECHADO



4A330C-10



4V330C-08

4A330-08

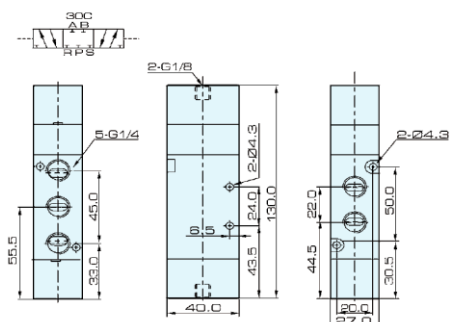

4A330-10

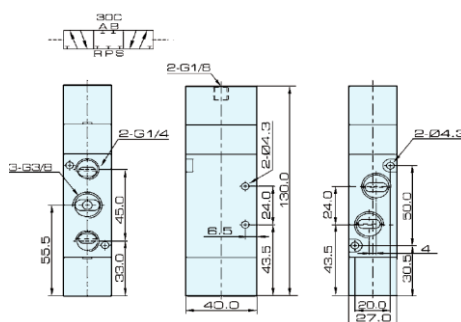

4V330-08

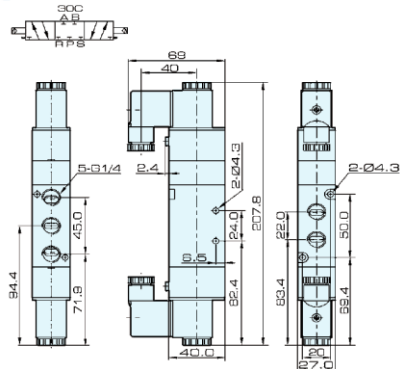

4V330-10

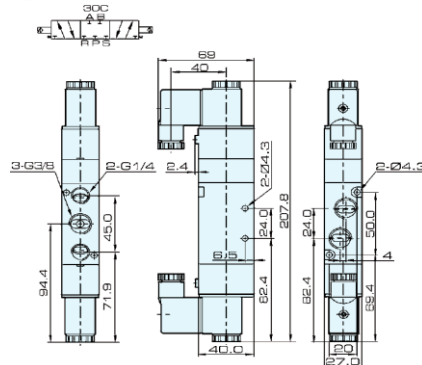

ESPECIFICAÇÕES

MODELO	4A330C-08	4A330C-10	4V330C-08	4V330C-10
ENTR/SAIDA	1/4"	3/8"	1/4"	3/8"
ESCAPE	1/4"	1/4"	1/4"	1/4"
ÁREA EQUIVALENTE	25mm ²	30mm ²	25mm ²	30mm ²
COEFICIENTE VAZÃO	1,40	1,68	1,40	1,68
FLUIDO	AR FILTRADO (40 µm)			
PRESSÃO	0,15 ~ 0,8 Mpa			
PRESSÃO MÁX.	1,2 MPa			
TEMPERATURA	5 ~ 50 °C			
CLASSE PROTEÇÃO	IP 65			
TENSÃO	12DC - 24DC - 110AC - 220 AC			
FREQUÊNCIA	5 CICLOS/s			
TEMPO RESPOSTA	0,05 s			

VÁLVULA SOLENÓIDE 5/3 VIAS CENTRO FECHADO



4A430C-15



4V430C-15

4A430-15

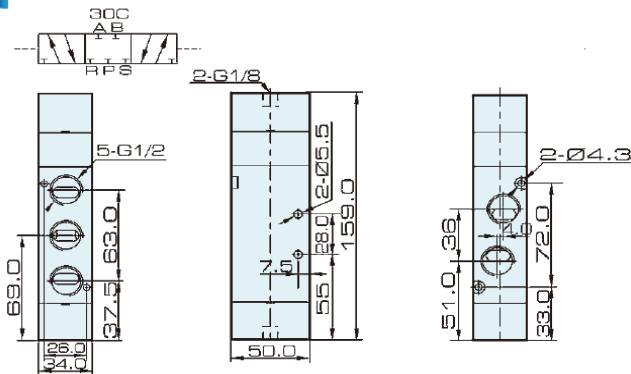

4V430-15

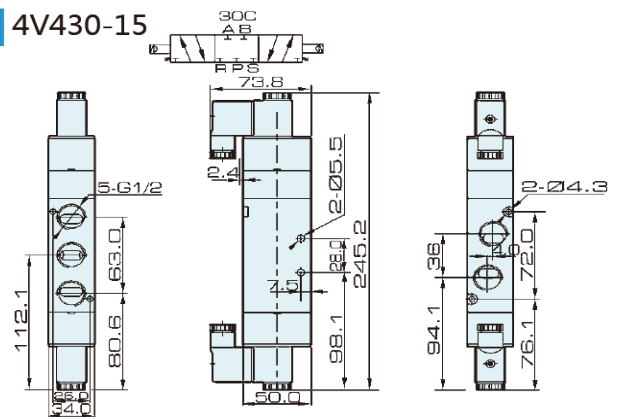

ESPECIFICAÇÕES		
MODELO	4A430C-15	4V430C-15
ENTR/SAIDA	1/2"	
ESCAPE	1/2"	
ÁREA EQUIVALENTE	50mm ²	
COEFICIENTE VAZÃO	2,79	
FLUIDO	AR FILTRADO (40 µm)	
PRESSÃO	0,15 ~ 0,8 Mpa	
PRESSÃO MÁX.	1,2 MPa	
TEMPERATURA	5 ~ 50 °C	
CLASSE PROTEÇÃO	IP 65	
TENSÃO	12DC - 24DC - 110AC - 220 AC	
FREQUÊNCIA	5 CICLOS/s	
TEMPO RESPOSTA	0,05 s	

VÁLVULA SOLENÓIDE 5/2 VIAS NAMUR



4V310-08B



4V310-10B

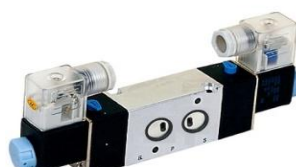

4V320-08B



4V320-10B

4V310-08B

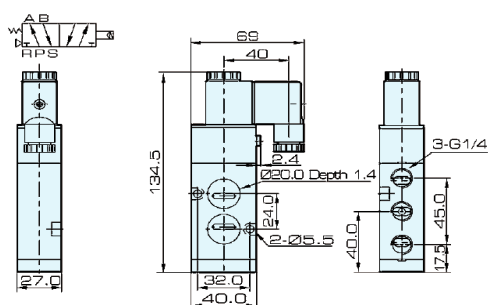

4V310-10B

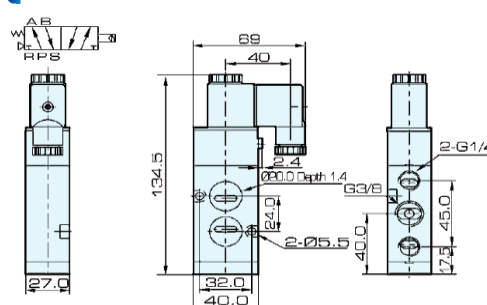

4V320-08B

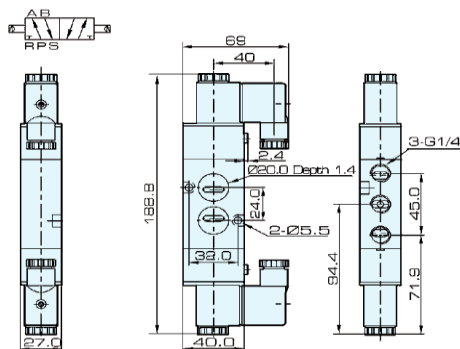

4V320-10B

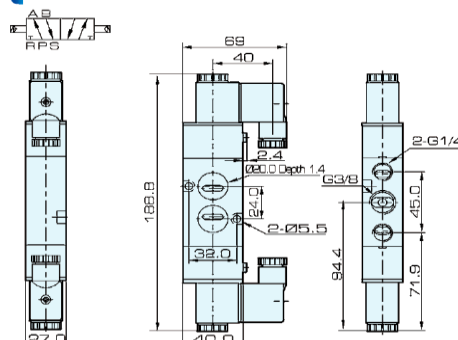

ESPECIFICAÇÕES

MODELO	4V310-08B	4V310-10B	4V320-08B	4V320-10B
ENTRADA/SAIDA	1/4"	3/8"	1/4"	3/8"
ESCAPE	1/4"	1/4"	1/4"	1/4"
ÁREA EQUIVALENTE	25mm ²	30mm ²	25mm ²	30mm ²
COEFICIENTE VAZÃO	1,40	1,68	1,40	1,68
FLUIDO	AR FILTRADO (40 µm)			
PRESSÃO	0,15 ~ 0,8 Mpa			
PRESSÃO MÁX.	1,2 MPa			
TEMPERATURA	5 ~ 50 °C			
CLASSE PROTEÇÃO	IP 65			
TENSÃO	12DC - 24DC - 110AC - 220 AC			
FREQUÊNCIA	5 CICLOS/s			
TEMPO RESPOSTA	0,05 s			

VÁLVULA SOLENÓIDE 5/2 VIAS NAMUR



4V410-15B



4V420-15B

4V410-15B

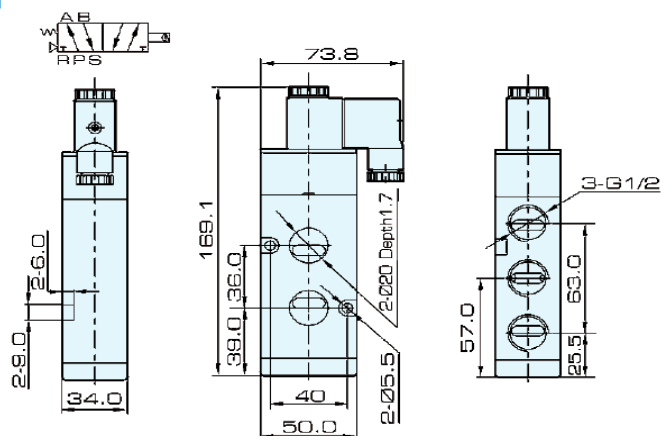

4V420-15B

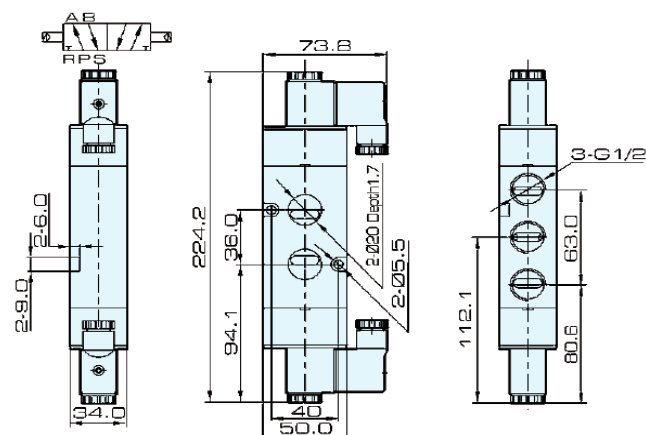

ESPECIFICAÇÕES		
MODELO	4V410-15B	4V420-15B
ENTR/SAIDA	1/2"	
ESCAPE	1/2"	
ÁREA EQUIVALENTE	50mm ²	
COEFICIENTE VAZÃO	2,79	
FLUIDO	AR FILTRADO (40 µm)	
PRESSÃO	0,15 ~ 0,8 Mpa	
PRESSÃO MÁX.	1,2 MPa	
TEMPERATURA	5 ~ 50 °C	
FREQUÊNCIA	5 CICLOS/s	
TEMPO RESPOSTA	0,05 s	

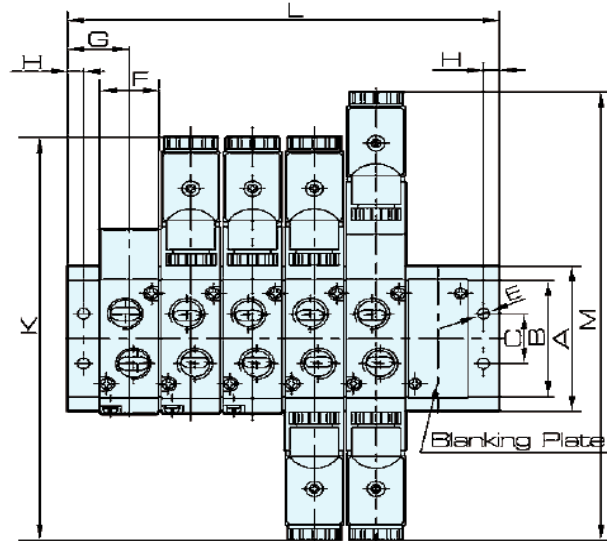
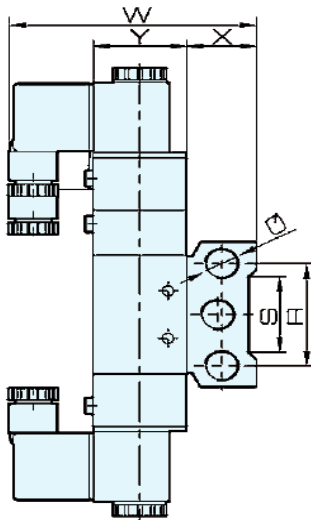

MODELO	A	B	C	E	F	G	H	K	L	M	Q	R	S	W	X	Y
200M-n	59	50	21	4,3	22,2	23	6	170	$(n-1)*23+46$	189	1/4"	43	32	92,5	26	35
300M-n	75	64	26	4,5	27,3	27	6	189	$(n-1)*28+54$	208	3/8"	53	48	99	30	40
400M-n	98	94	32	5,5	34,3	31,5	7	222	$(n-1)*35+63$	243	1/2"	68	67	112	38	50

n : número de válvulas

VÁLVULA SOLENÓIDE 3/2 VIAS



3V1-06



3V1-06A-2F

3V1-06

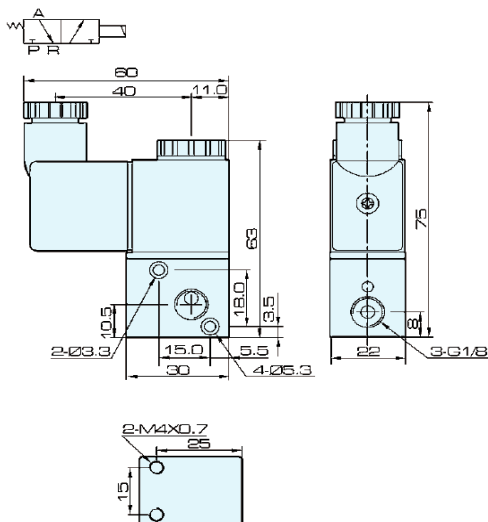

3V1-06A

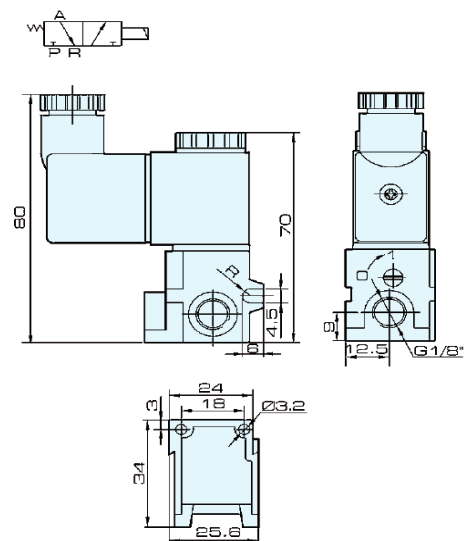

ESPECIFICAÇÕES		
MODELO	3V1-06	3V1-06A-2F
ENTR/SAIDA	1/8"	
ESCAPE	1/8"	
FLUIDO	AR FILTRADO (40 µm)	
PRESSÃO	0,15 ~ 0,8 Mpa	
PRESSÃO MÁX.	1,2 MPa	
TEMPERATURA	5 ~ 50 °C	
CLASSE PROTEÇÃO	IP 65	
FREQUÊNCIA	10 CICLOS/s	
TEMPO RESPOSTA	0,05 s	

VÁLVULA SOLENÓIDE 2/2 VIAS



2V025-08



2V130-15



2V250-25

ESPECIFICAÇÕES

MODELO	2V025-06	2V025-08	2V130-10	2V130-15	2V250-20	2V250-25
ENTR/SAÍDA	1/8"	1/4"	3/8"	1/2"	3/4"	1"
ORIFÍCIO	2,5 mm		13 mm		25 mm	
COEF. VAZÃO	0,23		6,2		23	
MATERIAL CORPO	ALUMÍNIO		LATÃO FORJADO		LATÃO FORJADO	
TIPO	NORMAL FECHADA					
FLUIDO	ÁGUA, AR E ÓLEO					
VISCOSIDADE MAX.	20 CST					
TEMPERATURA	- 10 a 80° C					
PRESSÃO TRABALHO	0,05 ~ 0,7 Mpa					
PRESSÃO MÁX	1,0 Mpa					
CLASSE PROTEÇÃO	IP 65					
POTÊNCIA	AC: 6,5 VA DC: 6,5W					
VEDAÇÃO	NBR OU VITON					
TEMPO RESPOSTA	0,05 s					

2V025

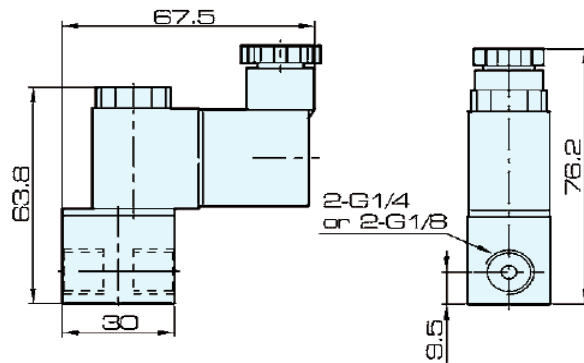
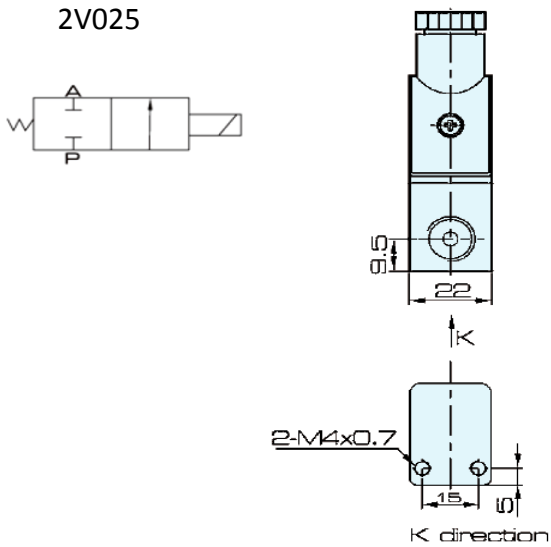

2V130

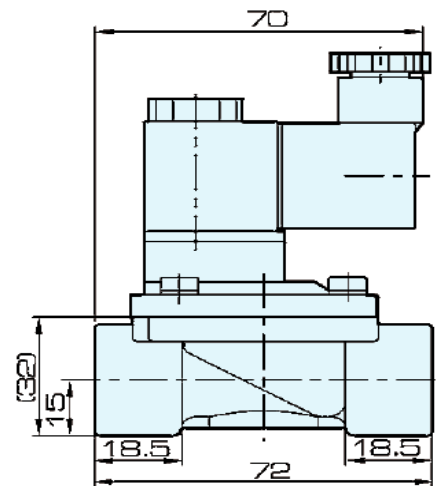
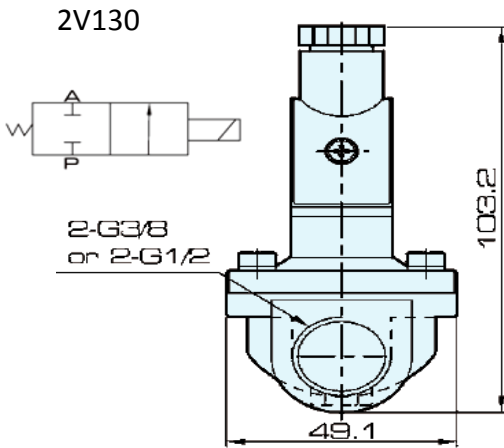

2V250

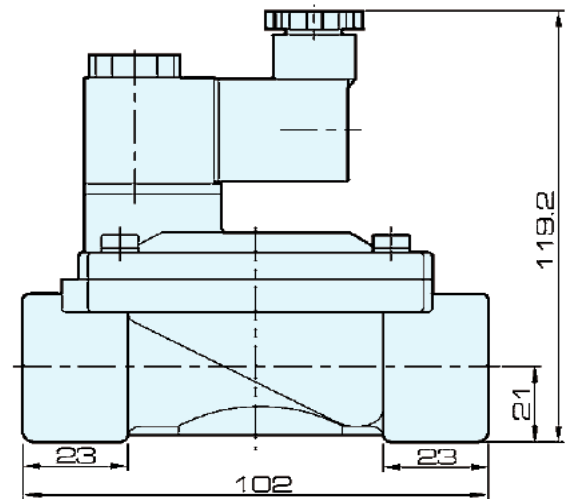
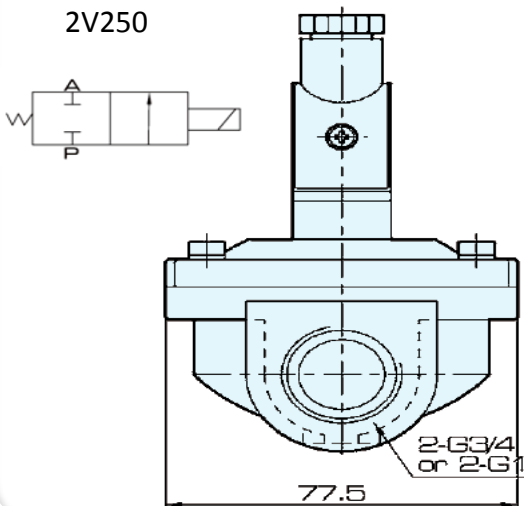



2W160-15



2S350-35



2W500-50

2W

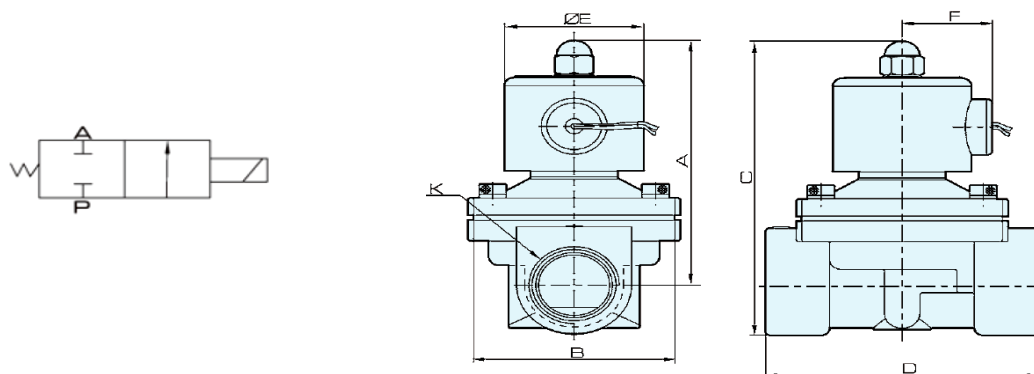

MODELO	A	B	C	D	E	F
2W160	101,5	57	117	69	50	36
2W200	107	57	123,5	73	50	36
2W250	111,5	73,5	134,5	99	50	36
2W350	142	95	172	123	70,5	56
2W400	142	95	172	123	70,5	56
2W500	172	123	209	168	70,5	56

ESPECIFICAÇÕES

MODELO	2W160-10	2W160-15	2W200-20	2W250-25	2W350-35	2W400-40	2W500-50
	2S160-10	2S160-15	2S200-20	2S250-25	2S350-35	2S400-40	2S500-50
ENTR/SAÍDA	3/8"	1/2"	3/4"	1"	1 1/4"	1 1/2"	2"
ORIFÍCIO	16 mm	16 mm	20 mm	25 mm	35 mm	40 mm	50 mm
COEF. VAZÃO	4,8	4,8	7,6	12	24	29	48
TIPO	NORMAL FECHADA						
FLUIDO	ÁGUA, AR E ÓLEO						
VISCOSIDADE MAX.	20 CST						
TEMPERATURA	- 5 a 80° C						
PRESSÃO TRABALHO	Ar: 0 ~ 0,7 Mpa - Água: 0 ~ 0,5 Mpa - Óleo: 0 ~ 0,5 Mpa						
PRESSÃO MÁX	1,0 Mpa						
VEDAÇÃO	NBR, EPDM OU VITON						
MATERIAL CORPO	2W: LATÃO FORJADO - 2S: AÇO INOX						



2L200-25



2L300-40

180° C

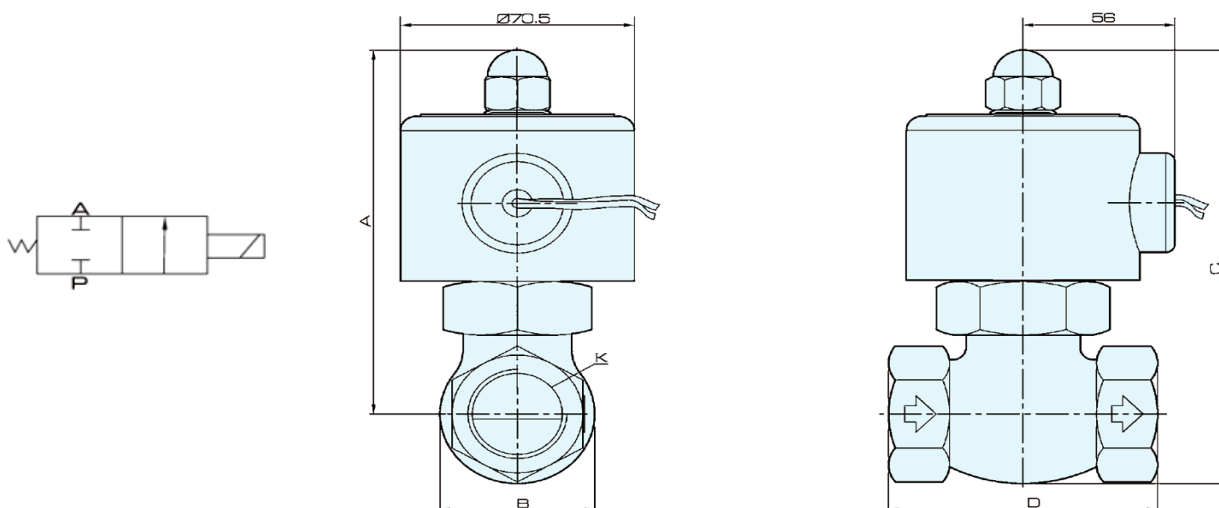

MODELO	A	B	C	D
2L170	125	42	146	82
2L200	136	52	162	90,5
2L300	148	74	185	111
2L500	176	86	223	163

ESPECIFICAÇÕES							
MODELO	2L170-10	2L170-15	2L170-20	2L200-25	2L300-35	2L300-40	2L500-50
ENTR/SAÍDA	3/8"	1/2"	3/4"	1"	1 1/4"	1 1/2"	2"
ORIFÍCIO	17 mm	17 mm	17 mm	22 mm	30 mm	30 mm	50 mm
COEF. VAZÃO	4,8	4,8	4,8	12	20	20	48
TIPO	NORMAL FECHADA						
FLUIDO	Vapor, Ar, Água e Óleo						
VISCOSIDADE MAX.	20 CST						
TEMPERATURA	- 5 a 180° C						
PRESSÃO TRABALHO	0,1 ~ 1,5 Mpa						
PRESSÃO MÁX	2,25 Mpa						
VEDAÇÃO	PTFE						
MATERIAL CORPO	LATÃO FORJADO						



2Q200-25



2Q500-50

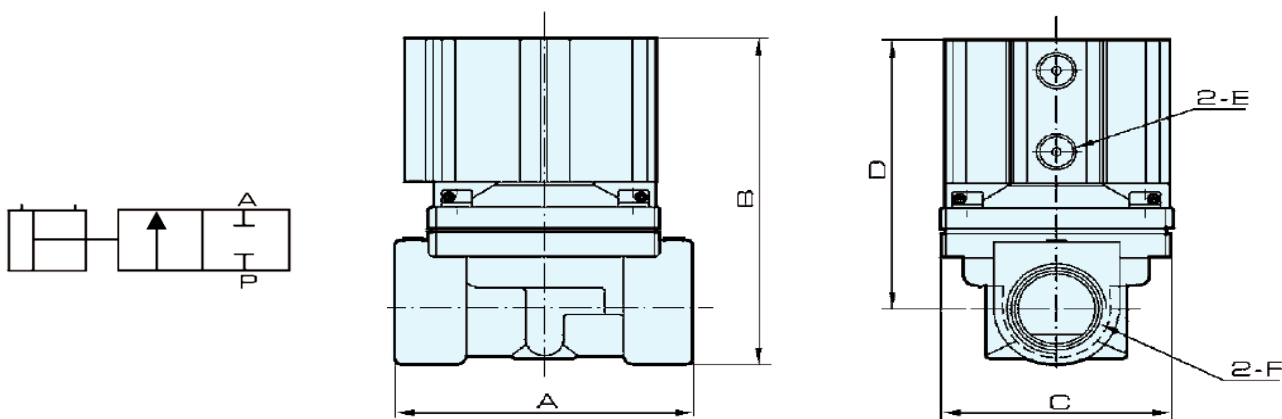

MODELO	A	B	C	D	E
2Q200	99	116	57	95	1/8"
2Q350	123	146	95	116	1/4"
2Q500	170	155	118	114	1/4"

ESPECIFICAÇÕES				
MODELO	2Q200-20	2Q200-25	2Q350-40	2Q500-50
ENTR/SAÍDA	3/4"	1"	1 1/2"	2"
ORIFÍCIO	22 mm	22 mm	35 mm	50 mm
COEF. VAZÃO	12	12	24	48
FLUIDO	Ar , Água , Óleo e Gases inertes			
VISCOSIDADE MAX.	50 CST			
TEMPERATURA	- 5 a 100° C			
PRESSÃO TRABALHO	0 ~ 0,7 Mpa			
PRESSÃO MÁX	1,05 Mpa			
VEDAÇÃO	PTFE			
MATERIAL CORPO	LATÃO FORJADO			



VALVULA FILTRO MANGA

Disponível nas bitolas G 1/2", G 3/4", G 1", G 1 1/4" e G 1 1/2", a válvula para filtro de manga possui acionamento contínuo normal aberta e normal fechada, com duas vias e duas posições, além de bobina à prova de explosão.

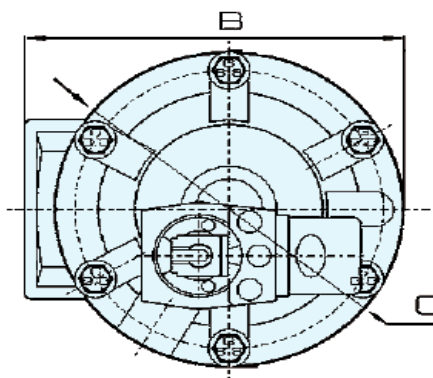
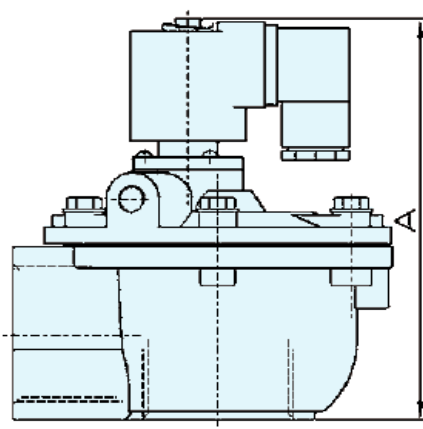

MODELO	A	B	C
JEL-Z-20	110	90,5	75
JEL-Z-25	110	90,5	75
JEL-Z-40S	166	132	137
JEL-Z-50S	202	210	185

ESPECIFICAÇÕES				
MODELO	JEL-Z-20	JEL-Z-25	JEL-Z-40S	JEL-Z-50S
ENTR/SAÍDA	3/4"	1"	1 1/2"	2"
ORIFÍCIO	Ø20 mm	Ø25 mm	Ø40 mm	Ø 50 mm
FLUIDO	AR			
TEMPERATURA	- 5 a 55° C			
PRESSÃO TRABALHO	0,3 ~ 0,8 Mpa			
HUMIDADE MÁX.	85%			



2K200-32



2K200-50

180° C

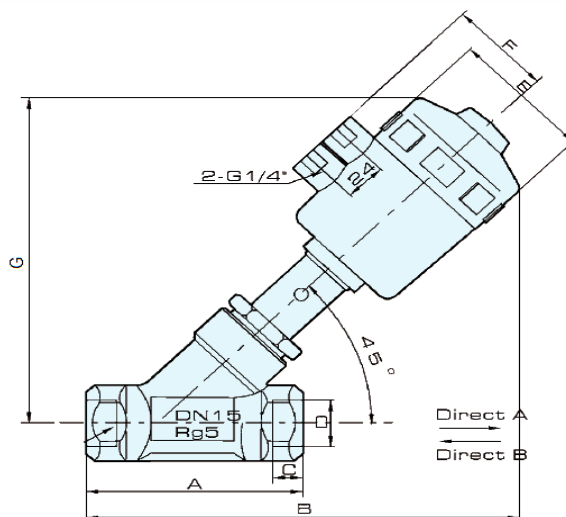
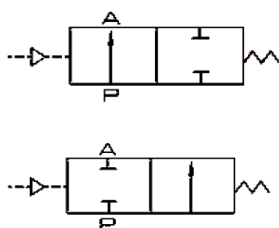

MODELO	A	B	C	D	E	F	G
2K200-15	85	173	12	1/2"	64	44	137
2K200-20	95	178	12	3/4"	64	44	145
2K200-25	105	212	14	1"	80	52	173
2K200-32	118	236	16	1 1/4"	80	52	189
2K200-40	130	230	18	1 1/2"	80	52	189
2K200-50	150	238	20	2"	100	52	250

ESPECIFICAÇÕES						
MODELO	2K200-15	2K200-20	2K200-25	2K200-32	2K200-40	2K200-50
ENTR/SAÍDA	1/2"	3/4"	1"	1 1/4"	1 1/2"	2"
ATUADOR	50	50	63	63	63	80
ORIFÍCIO	15 mm	20 mm	25 mm	32 mm	40 mm	50 mm
VAZÃO (m³/h)	4,2	8	19	27,5	42	55
PRESSÃO MÁX.	1,6 Mpa	1,1 Mpa	1,1 Mpa	1,5 Mpa	1,25 Mpa	1,0 Mpa
PRES. MIN. ACION.	0,39 Mpa	0,39 Mpa	0,42 Mpa	0,5 Mpa	0,44 Mpa	0,4 Mpa
FLUIDO	ÁGUA, AR, VAPOR, GAS INERTE E ÓLEO					
VISCOSIDADE MÁX.	50 CST					
TEMPERATURA	- 10 a 180° C					



4H210-08



4H230C-08



4H410-15

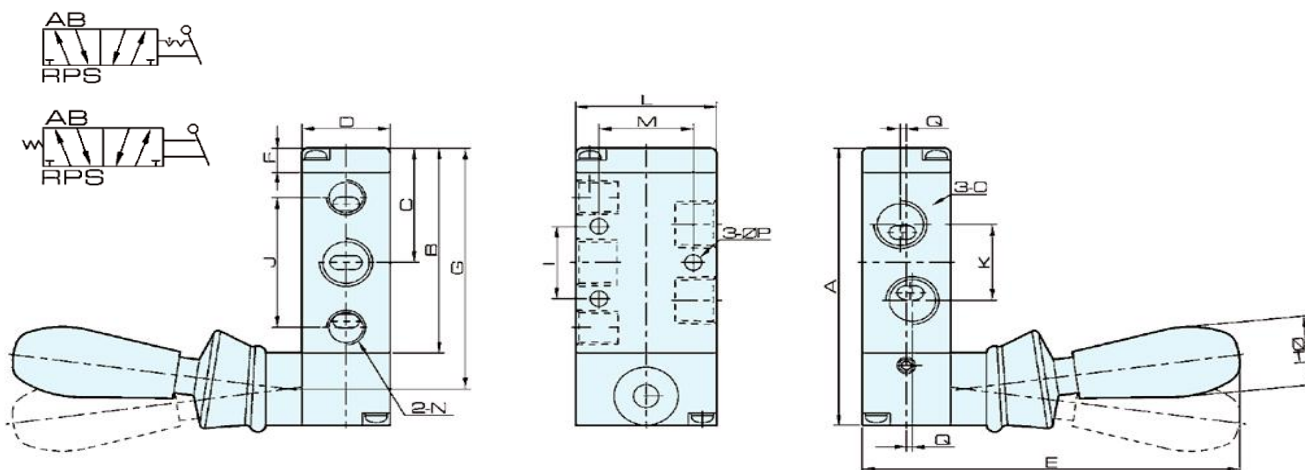

MODELO	5/2 VIAS	5/3 VIAS	5/2 VIAS	5/3 VIAS	5/2 VIAS	5/3 VIAS
	4H210-08	4H230C-08	4H310-010	4H330C-10	4H410-15	4H430C-15
A	76	95	96	115	126	147
B	56,5	75,5	72	91	102	123
C	31,5	31,5	40	60	55,5	76,5
D	22	22	27	27	34	34
E	95	95	100	100	110	110
F	6,5	6,5	7,5	7,5	7,5	7,5
G	66,5	85,5	84	103	114	135
H	18	18	18	18	18	18
I	20	20	24	24	28	28
J	36	36	45	45	63	63
K	21	21	24	24	36	36
L	35	35	40	40	50	50
M	21	21	27	27	35	35
N	1/8"	1/8"	3/8"	3/8"	1/2"	1/2"
O	1/4"	1/4"	3/8"	3/8"	1/2"	1/2"
P	4,3	4,3	4,3	4,3	5,5	5,5
Q	1,5	1,5	2	2	-	-

4HV230C-08

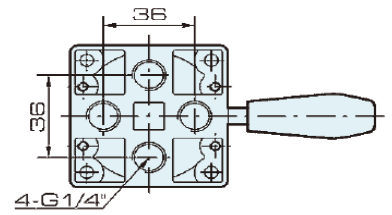
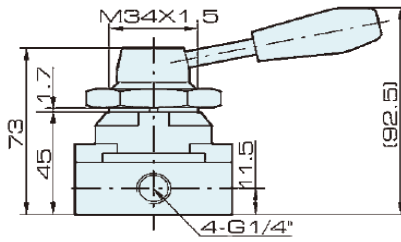
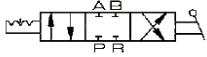

Base Installation

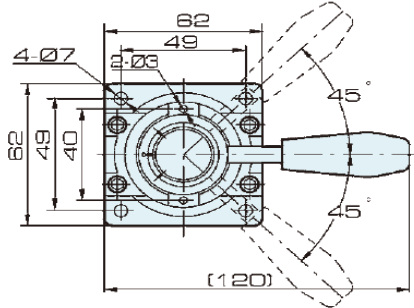

4HV330C-10

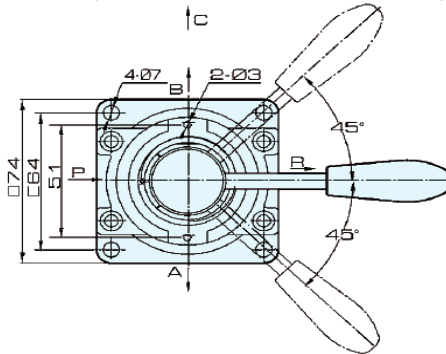
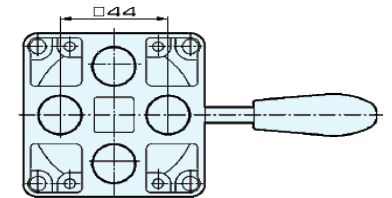
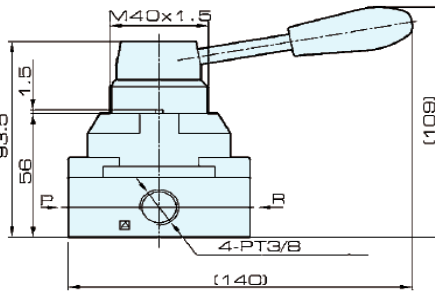

4HV430C-15

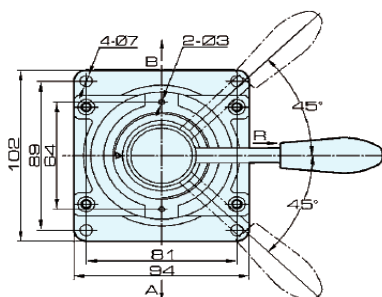
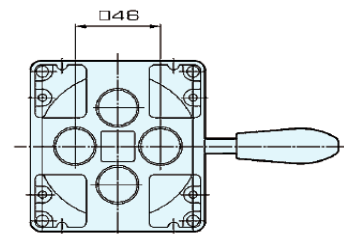
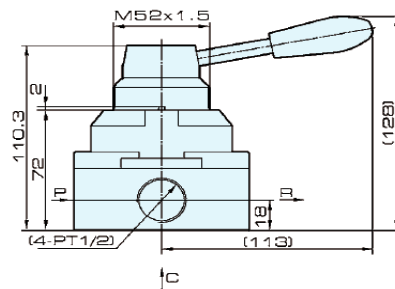

3R210-08

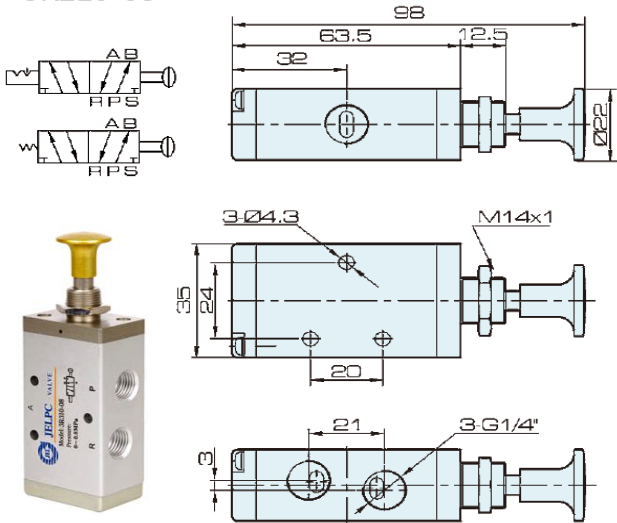

4R210-08

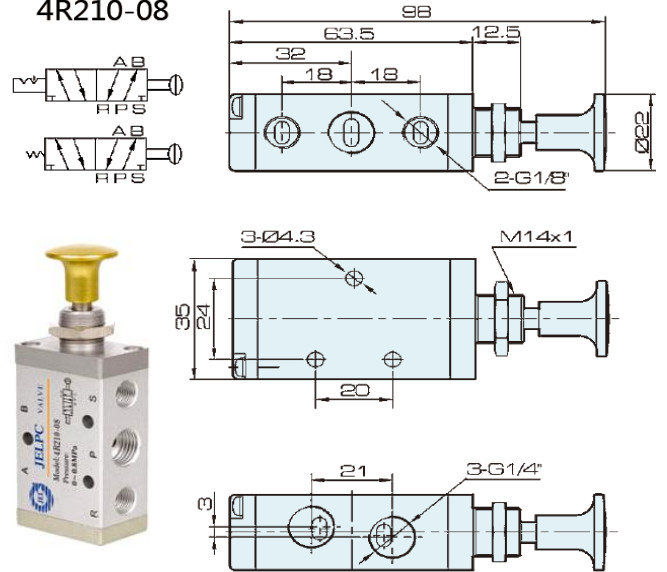

3R310-10

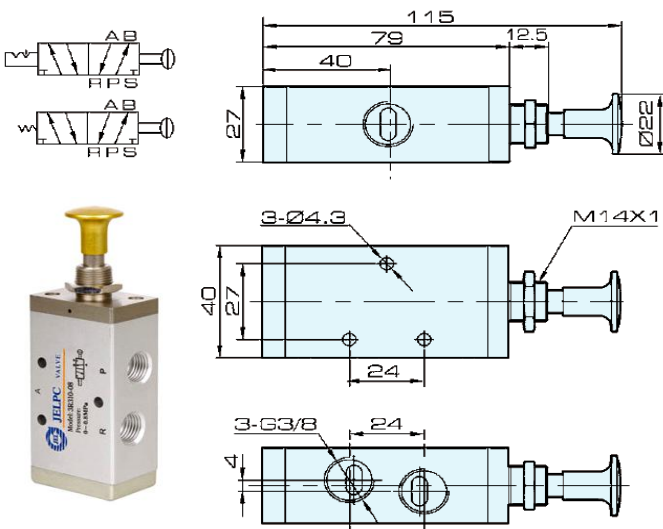

4R310-10

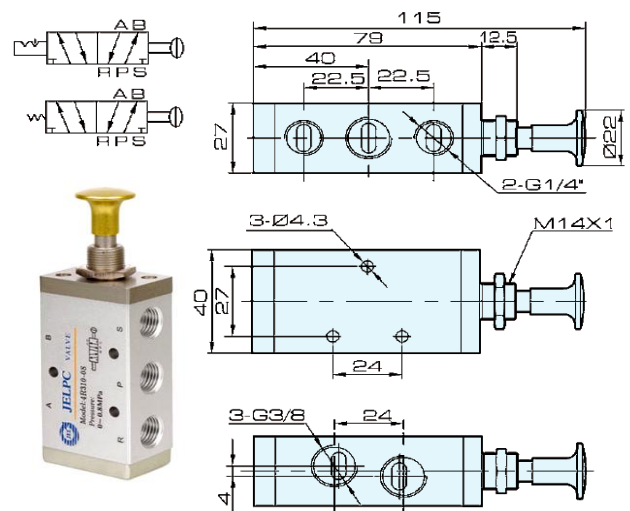

4F210-08

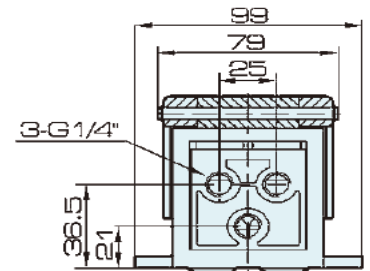
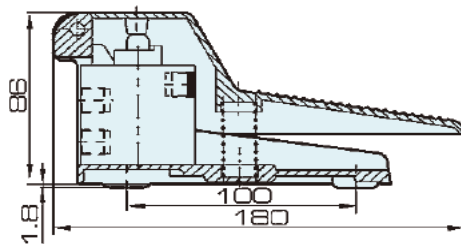

4F210-08L

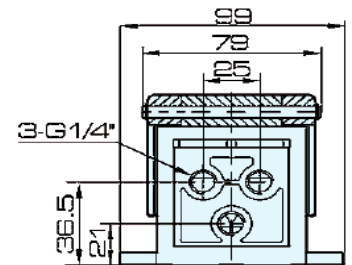
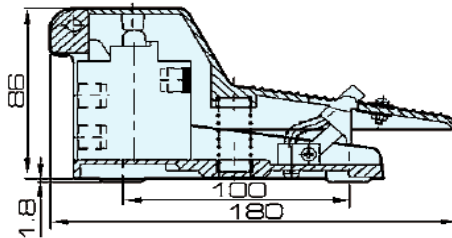

4F210-08G

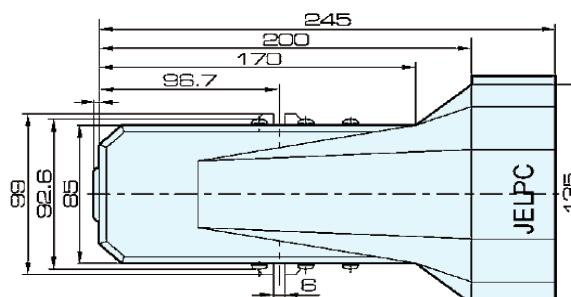
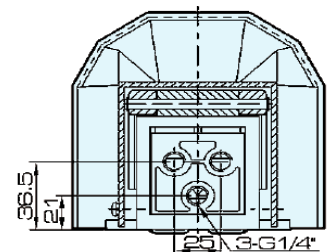
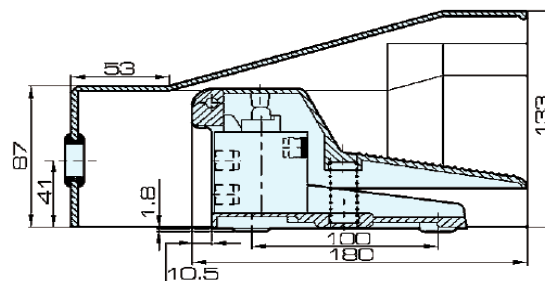

4F210-08LG

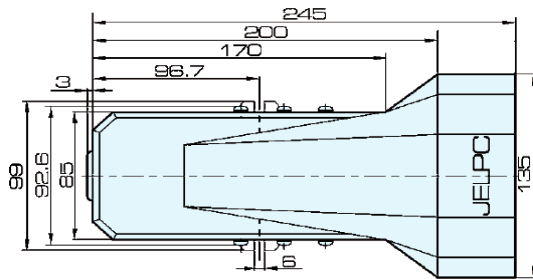
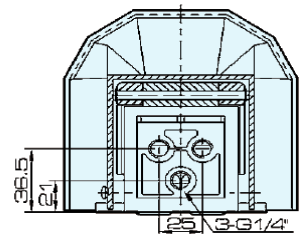
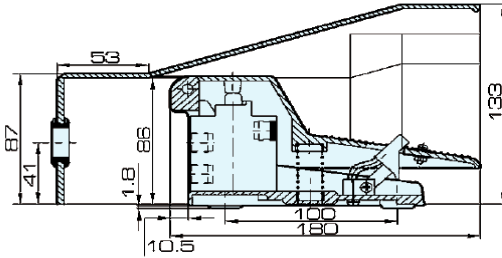

FV420

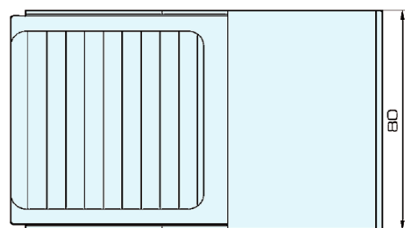
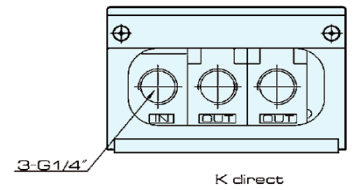
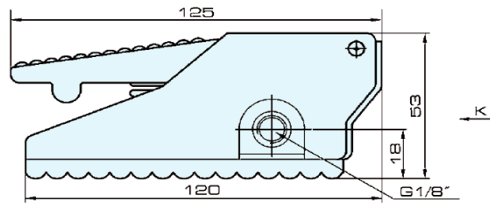
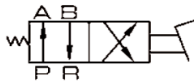

FV320

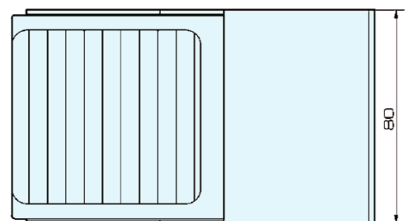
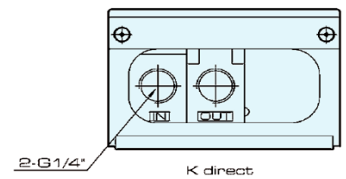
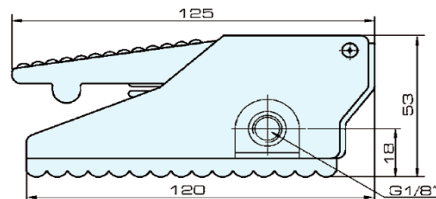

REGULADOR DE FLUXO



MODELO	ROSCA
ASC-06	1/8"
ASC-08	1/4"
ASC-10	3/8"
ASC-15	1/2"

VÁLVULA DE ESCAPE RÁPIDO



MODELO	ROSCA
QE-06	1/8"
QE-08	1/4"
QE-10	3/8"
QE-15	1/2"

VÁLVULA DESLIZANTE



MODELO	ROSCA
HSV-06	1/8"
HSV-08	1/4"
HSV-10	3/8"
HSV-15	1/2"

VÁLVULA DE ESCAPE RÁPIDO



MODELO	ROSCA
QEA-06	1/8"
QEA-08	1/4"
QEA-10	3/8"
QEA-15	1/2"

ELEMENTO "OU"



MODELO	ROSCA
ST-06	1/8"
ST-08	1/4"
ST-10	3/8"
ST-15	1/2"

VÁLVULA DE RETENÇÃO



MODELO	ROSCA
KA-06	1/8"
KA-08	1/4"
KA-10	3/8"
KA-15	1/2"

PURGADOR ELETRÔNICO



TIMER ANALÓGICO

