



ÍNDICE

	CILINDROS ISO	01
	ACESSÓRIOS - CANTONEIRA.	02
	ACESSÓRIOS - FLANGE.	02
	ACESSÓRIOS - ARTICULAÇÃO TRASEIRA MACHO.	03
	ACESSÓRIOS - ARTICULAÇÃO TRASEIRA FEMEA.	03
	ACESSÓRIOS - SUPORTE OSCILANTE.	04
	ACESSÓRIOS - PONTEIRAS MACHO/FEMEA.	04
	ACESSÓRIOS - PONTEIRA ROTULAR.	05
	ACESSÓRIOS - JUNTA FLUTUANTE.	05
	CILINDROS MINI ISO	06
	CILINDROS ACESSÓRIOS MINI ISO	07
	CILINDROS COMPACTOS	08

ESPECIFICAÇÕES

Cilindro: Dupla ação c/ amortecimento

Fluido: Ar filtrado e lubrificado

Êmbolo: Magnético

Pressão de trabalho: 1 a 9 bar

Pressão ruptura: 13,5 bar

Temp. de trabalho: -10 a 80°C



TABELA DE FORÇAS EM NEWTONS (N)					
Ø cilindro (mm)	Ø haste (mm)	Área efetiva (mm ²)		Força teórica a Pressão de 6 bar	
		Avanço	Retorno	Avanço(N)	Retorno(N)
32	12	804	691	482	414
40	16	1257	1056	754	633
50	20	1964	1649	1.178	989
63	20	3117	2803	1.869	1.681
80	25	5027	4536	3.014	2.720
100	25	7854	7363	4.710	4.416
125	32	12270	11470	7.359	6.877

Obs.: As forças são teóricas e podem sofrer alterações

DIMENSIONAL

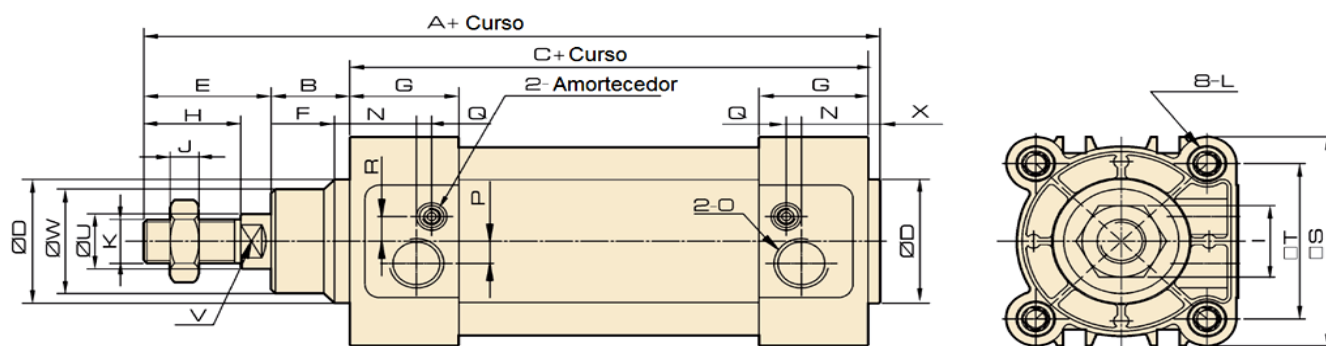

Ø	A	B	C	D	E	F	G	H	J	K	L	N	O	P	Q	R	S	T	U	V	W	X
32	142	16	94	30	33	4	25	22	6	M10X1,25	M6	15	1/8	5	3	6,5	45	32,5	12	10	25	4
40	159	20	105	35	34	4	29,5	24	7	M12X1,25	M6	17,5	1/4	7	3	7	52	38	16	13	33	4
50	175	27	106	40	42,5	5	32	32	8	M16X1,5	M8	20	1/4	7	3	9	65	46,5	20	17	36	4
63	190	26	122	45	42	5	36	32	8	M16X1,5	M8	22	3/8	8	5	9	76	56,5	20	17	38	4
80	214	35	127	45	53	6	37	40	10	M20X1,5	M10	23	3/8	10	5	12	94	72	25	22	43	5
100	229	40	137	55	52	6	39	40	10	M20X1,5	M10	26	1/2	10	5	14	112	89	25	22	43,5	6
125	277	46	160	60	71	10	43,5	54	40	M27X2	M12	29	1/2	10	5	14	134	110	32	27	53	7

CANTONEIRA

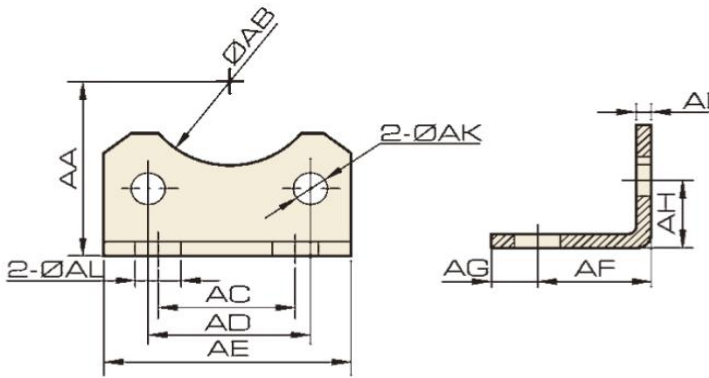

∅	32	40	50	63	80	100	125
AA	32	36	45	50	63	71	90
AB	30	35	40	45	45	55	60
AC	32	36	45	50	63	75	90
AD	32,5	38	46,5	56,5	72	89	110
AE	46,5	52,5	65	75	94,5	114,5	140
AF	24	28	32	32	41	41	45
AG	9	11	11	14	14	16	18
AH	15,8	17	21,8	21,8	27	26,5	35
AI	3,2	3,2	3,2	3,6	4,5	4,5	8
AK	6,5	6,5	8,5	8,5	10,5	10,5	12,5
AL	7	10	10	10	12	14,5	16,5

FLANGE

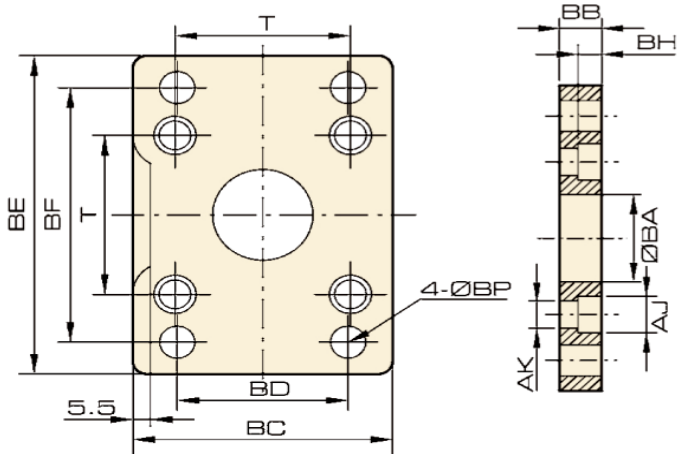

∅	32	40	50	63	80	100	125
BA	30,3	35,3	40,3	45,3	45,3	55,3	60,3
BB	10	10	12	12	16	16	20
BC	45	52	65	76	94	112	140
BD	32	36	45	50	63	75	90
BE	80	90,0	110	120	150	175,0	224
BF	64	72	90	100	126	150	180
BH	6,5	6,5	8,5	8,5	10,5	10,5	15
AJ	10,5	10,5	13,5	13,5	16,5	16,5	19
AK	6,5	6,5	8,5	8,5	10,5	10,5	12,5
BP	7	9	9	9	12	14	16
T	32,5	38	46,5	56,5	72	89	110

**ARTICULAÇÃO TRASEIRA
MACHO**

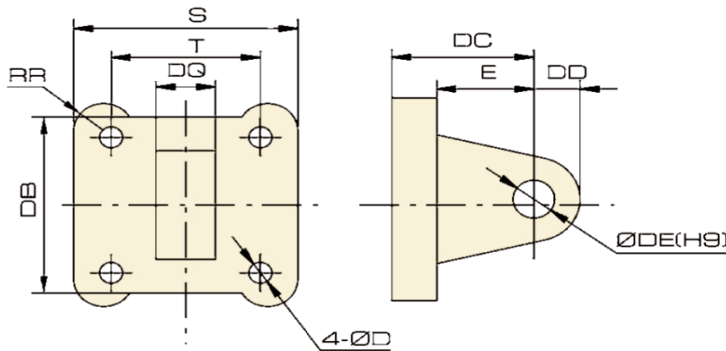

Ø	32	40	50	63	80	100	125
S	45	52	65	76	94	112	140
T	32,5	38	46,5	56,5	72	89	110
RR	6,5	6,5	9	9,5	11	11,5	12
DB	34	41	54	65	83	101	123
DC	22	25,0	27	32	36,0	41	50
DD	10	11	13	16	16	20	25
DE	10	12	12	16	16	20	25
DQ	26	28	32	40	50	60	70
D	6,5	6,5	8,5	8,5	10,5	10,5	12,5
E	14	17	17	22	24	25	30

**ARTICULAÇÃO TRASEIRA
FEMEA**

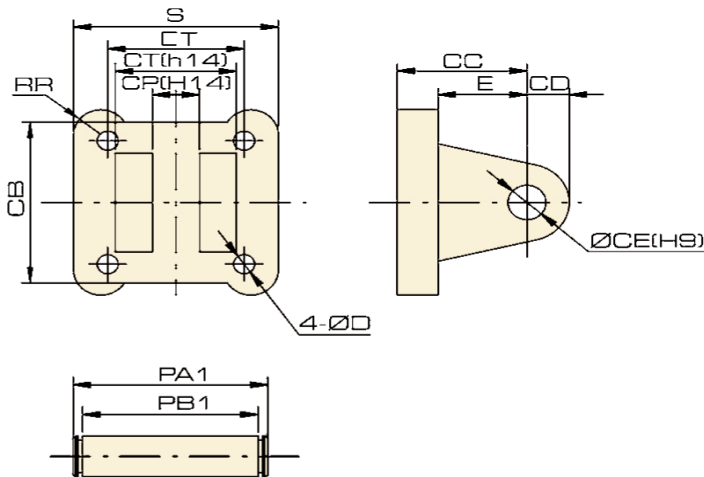

Ø	32	40	50	63	80	100	125
S	45	52	65	76	94	112	140
T	32,5	38	46,5	56,5	72	89	110
D	6,5	6,5	8,5	8,5	10,5	10,5	12,5
E	14	17	17	22	24	25	30
RR	6,5	6,5	9	9,5	11	11,5	12
CB	34	41	54	65	83	101	123
CC	22	25	27	32	36	41	50
CD	10	11	13	16	46	20	25
CE	10	12	12	16	16	20	25
CP	26	28	32	40	50	60	70
CT	45	52	60	70	90	110	120
PA1	53	60	68	78	100	120	130
PB1	46,5	53,5	61,5	71,5	91,5	111,5	121,5



SUPORTE OSCILANTE

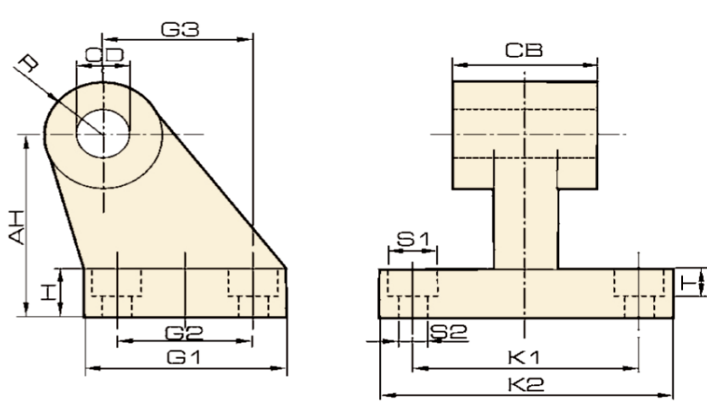

∅	32	40	50	63	80	100	125
AH	32	36	45	50	63	71	90
H	8	10	12	12	14	15	20
CD	10	12	12	16	16	20	25
G1	31	35	45	50	60	70	90
G2	18	22	30	35	40,0	50	60
G3	21	24	33	37	47	55	70
CB	26	28	32	40	50	60	70
K1	38	41	50	52	66	76	94
K2	51	54	65	67	86	96	124
S1	11	11	14	14	17	17	20
S2	6,6	6,6	9	9	11	11	14
T	1,6	1,6	1,6	1,6	2,5	2,5	3,2
R	10	11	13	15	15	19	22,5

PONTEIRA FEMEA

PONTEIRA MACHO

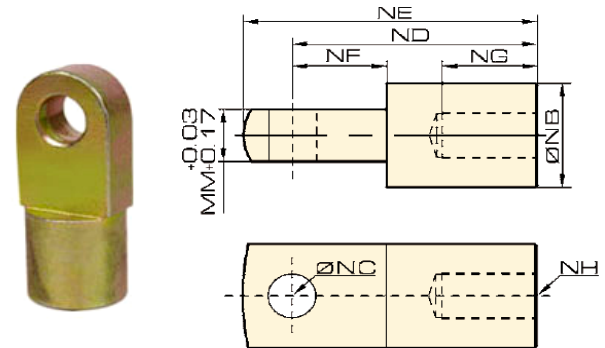
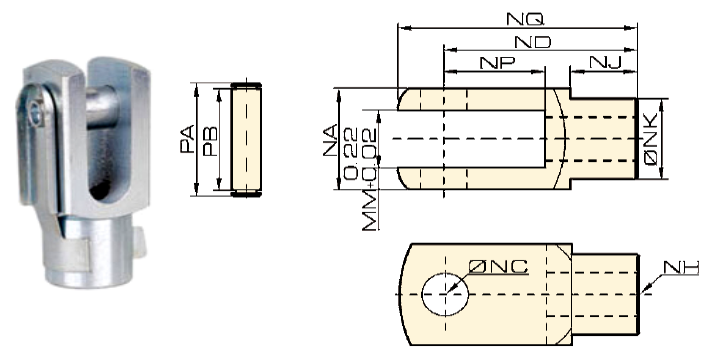

∅	NA	NB	NC	ND	NE	NF	NG	NH	NJ	NK	MM	NP	NQ	PA	PB
32	19	20	10	40	52	15	20	M10X1,25	15,5	16	10	20	52	26,2	20
40	24	24	12	48	67	24	20	M12X1,25	20,5	20	12	24	62	32,8	26,5
50	32	32	16	64	89	32	23	M16X1,5	26	30	16	32	83	39,3	33
63	32	32	16	64	89	32	23	M16X1,5	26	30	16	32	83	39,3	33
80	40	40	20	80	112	40	30	M20X1,5	30	38	20	39,5	105	53,3	45
100	40	40	20	80	112	40	30	M20X1,5	30	38	20	39,5	105	53,3	45
125	62	49	20	99	122	54	50	M27X2	28	38	30	34	120	75	66

PONTEIRA ROTULAR

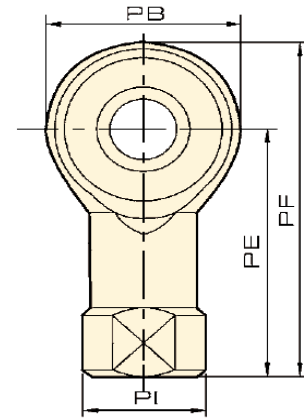
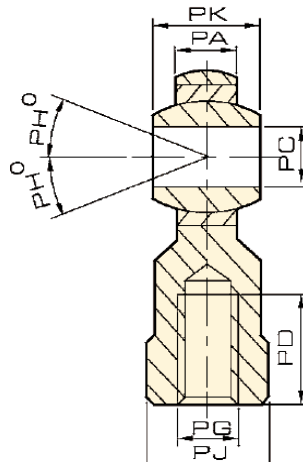

∅	PA	PB	PC	PD	PE	PF	PG	PH	PI	PJ	PK
32	11	26	10	20	43	56	M10X1,25	13	19	17	14
40	12	32	12	24	50	66	M12X1,25	13	22	19	16
50	15	40	16	28	64	84	M16X1,50	15	27	22	21
63	15	40	16	28	64	84	M16X1,50	15	27	22	21
80	18	46	20	35	77	100	M20X1,50	15	34	30	25
100	18	46	20	35	77	100	M20X1,50	15	34	30	25

JUNTA FLUTUANTE

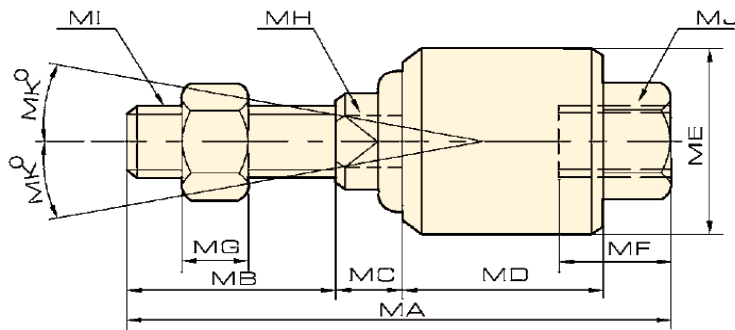

∅	MA	MB	MC	MD	ME	MF	MG	MH	MI	MJ	MK
32	58	22	7	21	26	11,5	7	10	M10X1,25	M10X1,25	12
40	58	22	8	21	28	11,5	8	12	M12X1,25	M12X1,25	12
50	90	27	10	41	44,5	20	10	17	M16X1,50	M16X1,50	7
63	90	27	10	41	44,5	20	10	17	M16X1,50	M16X1,50	7
80	102	29	13	46	53	24	13	22	M20X1,50	M20X1,50	10
100	102	29	13	46	53	24	13	22	M20X1,50	M20X1,50	10

ESPECIFICAÇÕES

Cilindro: Dupla ação c/ amortecimento

Fluido: Ar filtrado e lubrificado

Êmbolo: Magnético

Pressão de trabalho: 1 a 9 bar

Pressão Ruptura: 13,5 bar

Temp. de trabalho: -10 a 80°C



TABELA DE FORÇAS EM NEWTONS (N)					
Ø cilindro (mm)	Ø haste (mm)	Área efetiva (mm ²)		Força teórica a Pressão de 6 bar	
		Avanço	Retorno	Avanço(N)	Retorno(N)
12	6	113	85	68	51
16	8	201	151	121	90
20	10	314	236	188	141
25	10	491	412	294	247

Obs.: As forças são teóricas e podem sofrer alterações de acordo com as condições de trabalho.

DIMENSIONAL

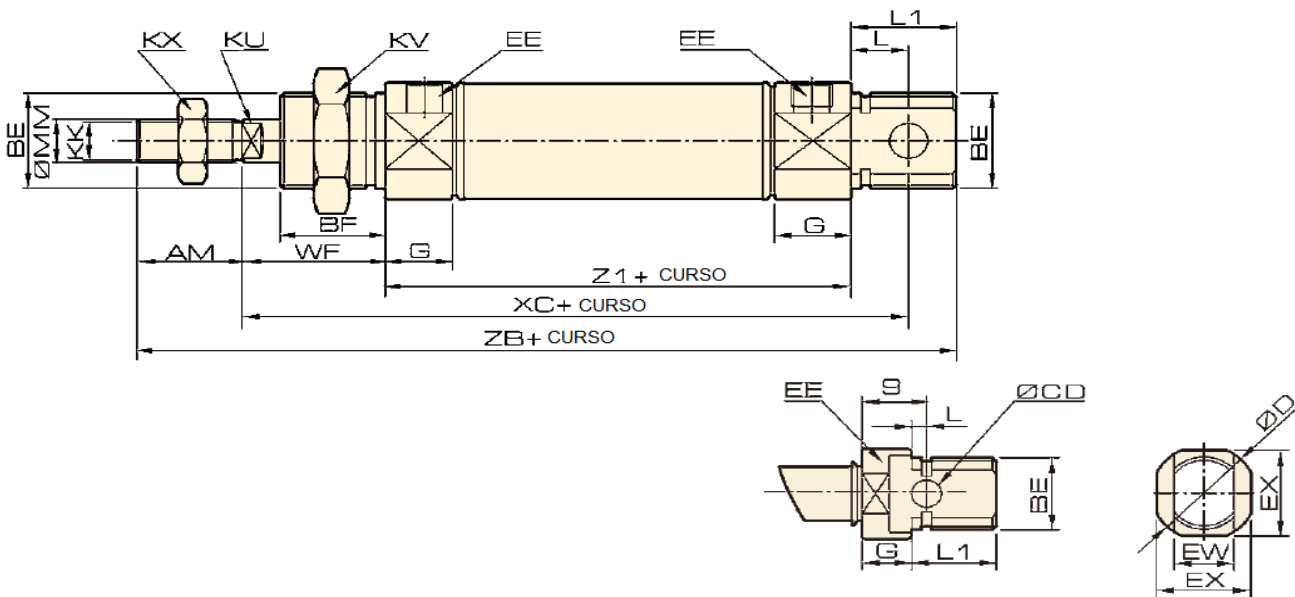

Ø	AM	BE	BF	CD	D	EE	EX	EW	G	KK	KU	KV	KX	L	L1	MM	WF	XC	Z1	ZB
12	16	M16X1,5	16	6	21	M5	18	12	10	M6X1,0	5	24	12	4	16	6	22	75	51	105
16	16	M16X1,5	16	6	21	M5	18	12	10	M6X1,0	5	24	12	9	16	6	22	89	51	105
20	20	M22X1,5	18	8	30	1/8"	27	16	15	M8X1,25	7	27	14	12	22	8	24	95	59	125
25	22	M22X1,5	20	8	30	1/8"	27	16	16	M10X1,25	9	27	17	12	22	10	28	104	64	136

CANTONEIRA

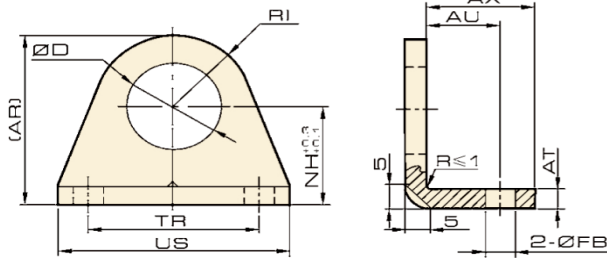

Ø	12	16	20	25
AT	4	4	5	5
AU	14	14	17	17
AX	20	20	25	25
FB	6	6	7	7
NH	20	20	25	25
TR	32	32	40	40
US	42	42	54	54
D	16,3	16,3	22,3	22,3
AR	32,5	32,5	42	42
RI	R12,5	R12,5	R17	R17

FLANGE

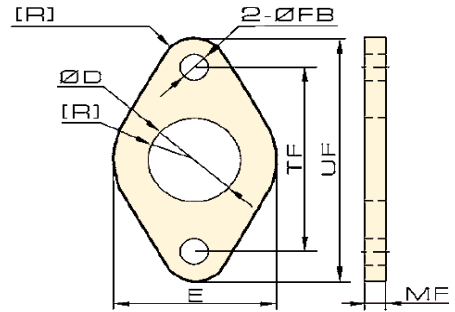

Ø	12	16	20	25
E	30	30	40	40
FB	6	6	7	7
MF	4	4	5	5
TF	40	40	50	50
UF	53	53	66	66
D	16,3	16,3	22,3	22,3

**ARTICULAÇÃO TRASEIRA
FEMEA**

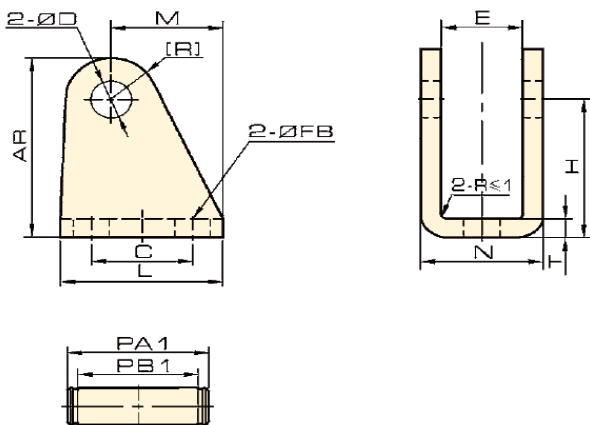

Ø	12	16	20	25
C	15	15	20	20
FB	6	6	7	7
H	27	27	30	30
L	25	25	32	32
M	18	18	22	22
N	18	18	25	25
E	12	12	16	16
T	3	3	4	4
D	6	6	8	8
AR	34	34	39	39

**SDA
(HASTE ROSCA FEMEA)**



**SDA - B
(HASTE ROSCA MACHO)**



ESPECIFICAÇÕES										
∅ (mm)	12	16	20	25	32	40	50	63	80	100
ALIMENTAÇÃO	M5X0,8				1/8"		1/4"		3/8"	
ACIONAMENTO	DUPLA AÇÃO									
PRESSÃO TRAB.	1 a 9 bar									
PRESSÃO MAX.	10,5 bar									
TEMP. TRABALHO	- 10 a 80 °C									

∅ mm	CURSO PADRÃO (mm)																
	5	10	15	20	25	30	40	50	80	100	125	160	200	250	320	400	500
12	•	•	•	•	•	•	•	•	•	•	•	•	•	X	X	X	X
16	•	•	•	•	•	•	•	•	•	•	•	•	•	X	X	X	X
20	•	•	•	•	•	•	•	•	•	•	•	•	•	X	X	X	X
25	•	•	•	•	•	•	•	•	•	•	•	•	•	X	X	X	X
32	•	•	•	•	•	•	•	•	•	•	•	•	•	•	•	X	X
40	•	•	•	•	•	•	•	•	•	•	•	•	•	•	•	X	X
50	•	•	•	•	•	•	•	•	•	•	•	•	•	•	•	X	X
63	•	•	•	•	•	•	•	•	•	•	•	•	•	•	•	•	•
80	•	•	•	•	•	•	•	•	•	•	•	•	•	•	•	•	•
100	•	•	•	•	•	•	•	•	•	•	•	•	•	•	•	•	•